

Design and Implementation of CNC Based Automatic Stamp Batik Machine

by Dhananjaya Kumarajati

Submission date: 26-Apr-2021 06:11AM (UTC+0700)

Submission ID: 1569494880

File name: nd_Implementation_of_CNC_Based_Automatic_Stamp_Batik_Bachine.pdf (1.09M)

Word count: 2523

Character count: 13019

PAPER • **OPEN ACCESS**

Design and Implementation of CNC (Computer Numerical Control) Based Automatic Stamp Batik Machine Program with Automatic Gripper Using Mach 3

² To cite this article: Theofilus Bayu Dwinugroho *et al* 2019 *J. Phys.: Conf. Ser.* **1254** 012069

View the [article online](#) for updates and enhancements:



240th ECS Meeting ORLANDO, FL

Orange County Convention Center Oct 10-14, 2021

Abstract submission deadline extended: April 23rd

SUBMIT NOW

Design and Implementation of CNC (Computer Numerical Control) Based Automatic Stamp Batik Machine Program with Automatic Gripper Using Mach 3

Theofilus Bayu Dwinugroho¹, Dhananjaya Yama Hudha Kumarajati²,
Kurniawanti³, Yaning Tri Hapsari⁴

Universitas PGRI Yogyakarta, DI. Yogyakarta, Indonesia

[1theofilus@upy.ac.id](mailto:theofilus@upy.ac.id), [2dhananjaya@upy.ac.id](mailto:dhananjaya@upy.ac.id), [3wanti.kurnia@upy.ac.id](mailto:wanti.kurnia@upy.ac.id),
[4yaning.yth@upy.ac.id](mailto:yaning.yth@upy.ac.id)

Abstract. Batik is a painting or drawing on mori fabric that is made with canting tools. In Subsequent developments to speed up the process, stamp batik is used. CNC (Computer Numerical Control) based automatic stamp batik machine has been developed. This machine uses a manual batik stamper in the batik stamp (tool). The problem that arises in the use of manual chucking on this automatic stamp batik machine is the amount of time needed in the replacement and setting of the batik stamp. The design of a CNC based automatic batik machine with automatic gripper has been developed. This automatic gripper combined with the CNC based automatic stamp batik machine is programmed using a combination of G-Code for the CNC and ladder diagram for the PLC (Programmable Logic Control). Based on the design that has been applied to batik stamps produced stamping that is more consistent and has better accuracy than manual stamping. The average difference in wax thickness is 0,003 mm and has 75 seconds slower than manual stamping. This means that even though the automatic gripper provides better accuracy and precision, it sacrifices stamping times.

1. Introduction

Batik is included in the textile industry. Batik is a painting or drawing on mori fabric made with canting aids, in subsequent developments to speed up the processing of the stamp used [1]. The cap batik industry has unique characteristics, namely the household / small / medium scale home industry, limited capital, order-based production, sub-production / outsourcing of fellow entrepreneurs, business relations of traders and entrepreneurs, traditional manual production equipment, business carried out for generations, creative and a major source of income [2]. The constraints that occur at this time are starting to reduce the interest of the younger generation in continuing the art and business of batik, especially in stamped batik so that there are less human resources in development and the production of traditional batik [3]. Operators who already have the ability as a stamper are also very rare in the labor market, even though the number of stamp operators is one of the main factors to increase the production capacity of batik companies. The number of stamp operators usually measures the size of the batik company. So it is necessary to increase the production capacity of batik printing [4]. In the 1990s came the influence of printing batik or textiles with batik motifs which resulted in many batik makers and stamps reducing their activities or closing their companies [5].

Automation has been carried out in the batik production process related to the problems faced by the batik industry today. CNC machine-controlled automatic stamp batik machines have been developed [6][7][8] this machine uses manual chuck in a batik stamp. A Computer cannot be directly connected to a CNC Machine. The computer is connected to an interface. This converts the signals from the computer to form that the CNC machine understands. The signals are in the form of a digital signal when they are sent to the CNC machine. The signals from the motors control interface on the CNC machine. The



Content from this work may be used under the terms of the Creative Commons Attribution 3.0 licence. Any further distribution of this work must maintain attribution to the author(s) and the title of the work, journal citation and DOI.

signals determine the way the vice moves. The vice moves in three directions X, Y and Z (Horizontally, vertically and depth). [9] Most of the CNC machines on this planet are still controlled by the G-code format of the NC program, which is standardized by ISO 6983 from 1983 [10][11]. The problem that arises in the use of manual chucking on this automatic stamp batik machine is the amount of time needed for replacement and setting the batik stamp [12]. The replacement of a batik stamp is done if you want to taste for different batik patterns/motifs or to combine batik patterns/motifs and colors. Based on previous research, customers prefer batik with more than one type of motif and color [6]. Batik stamp must be installed in parallel/not tilted position on the surface of the fabric so that in the installation it is necessary to use a spirit level as a reference, and the batik stamp must be installed parallel to the width of the fabric so that the resulting pattern is not tilted. The time needed to set it up to the correct position depends on the condition of the stamp, especially the handle and stalk cap [13]. To overcome the above-related setting and time of installation and tool replacement, in this case, the batik stamp, PLC-based automatic gripper has been developed [14]. The design and implementation of the G-Code program on this CNC machine use Mach 3, where the purpose of this CNC programming is to get accurate and precise batik tasting.

2. Method

This research and development method (R & D) method, which is a strategy or research method of processes or steps to develop a new product or refine existing products to be accountable. This research is part of the research related to Automation of Batik Cap Machine, where the automation research procedure is carried out gradually following the steps of Industrial Design Process (IDP) [15]. The research procedures for Automated Batik Stamp Machine are as follows:

- (1). Investigation of customer needs.
- (2). Conceptualization
- (3). Preliminary refinement
- (4). Further refinement and final conception
- (5). Control drawings
- (6). Coordinating with engineering, manufacturing, and vendors
 - a. The gripper prototype manufacturing process is based on the image that has been made
 - b. Evaluation of the motion system and physical gripper prototype
 - c. Installation of a control system (PLC) in the gripper
 - d. Mounting the gripper on the batik stamp machine
 - e. The gripper setting on the cap batik machine
 - f. The gripper performance test is related to the replacement of the batik stamp automatically, the correct position reference setting on the batik stamp, the time to replace the batik stamp and the results testing.
 - g. Documentation of results and stamping process
 - h. Conclusions and recommendations

The design and implementation of CNC programs using Mach 3 are carried out in step 6.f, namely in the gripper performance testing, related to the position reference and tasting settings. The tasting pattern will be made using two batik stamp where the automatic gripper will do the replacement of the batik stamp. And for the tasting itself use a 3x3 pattern as shown in Figure 1 below. From the 3x3 pattern is realized by manually tasting by batik stamp craftsmen. From the manual tasting, a tasting layout and movement patterns using Mach 3 in Figure 2 are made

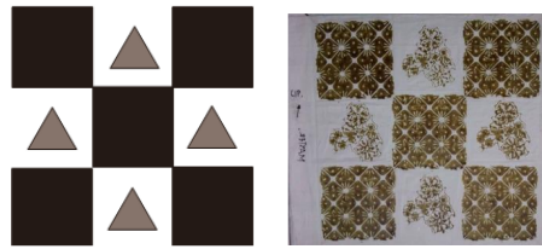

Figure 1. 3x3 pattern and manual stamping by batik craftsmen

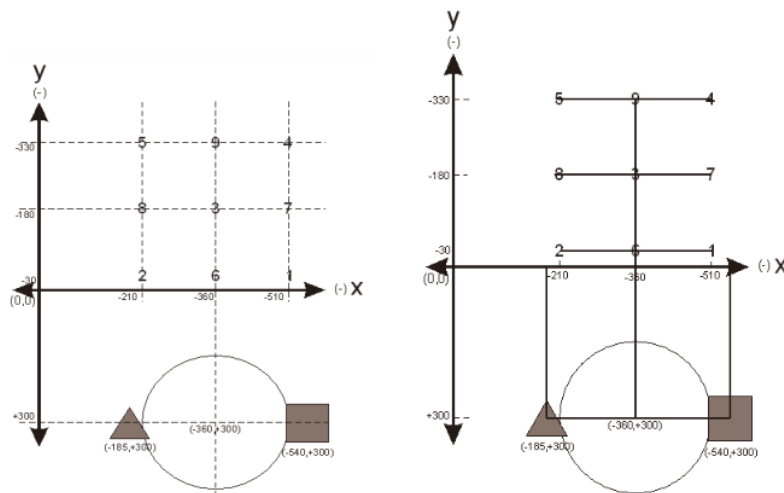

Figure 2. Picture of stamping layout and pattern of stamp movement on CNC-based automatic batik machines

3. Results and Discussions

The stamping sequence starts from the stamping of the rectangular batik stamp in the order as in the picture above, which starts at number 1, 2, 3, 4 and 5. The order of the taste of the batik triangle stamp starts from nos. 6, 7, 8 and 9. Steps stamping on the CNC machine G-Code program has four repetitive principal movements in each stamping activity of a pattern, namely:

a. Installation of the cap, in this step, is indicated by the G-code as follows:

```
g0 x-540 y+300 z0
g0 x-540 y+300 z-13
m3 x-540 y+300 z-13
g0 x-540 y+300 z0
```

In this step, the gripper moves (g0) towards the x-540, y + 300 axis then moves towards the z-13 axis. After reaching that point, the gripper grips the batik stamp (m3), then moves (g0) towards the x-540 axis, y + 300.

b. Release cap, in this step, is indicated by G-code as follows:

```
g0 x-540 y+300 z0
g0 x-540 y+300 z-13
m5 x-540 y+300 z-13
g0 x-540 y+300 z0
```

In this step, the gripper moves (g0) towards the x-540, y + 300 axis then moves towards the z-13 axis. After reaching that point, the gripper releases the stress on the batik stamp (m5), then moves (g0) towards the x-540 axis, y + 300.

c. Liquid wax dyeing, in this step, is indicated by the G-code as follows

```
g0 x-360 y+300 z0  
g0 x-360 y+300 z-41  
g0 x-360 y+300 z-20  
g0 x-360 y+300 z-41  
g0 x-360 y+300 z0
```

In this step, the gripper moves (g0) towards the liquid wax pad that is towards the x -360 axes, y + 300, positioned directly above the bearing, then moves towards the z-41 axis, down to the bearing to dip the batik stamp on the liquid wax pad. This dyeing movement repeats two times and then moves again (g0) towards the x-360, y + 300, z0 axis (position just above the bearing). Then the stamping and containment steps are continued

d. Locking and stopping stamp, in this step is indicated by the G-code as follows:

```
g0 x-510 y-30 z0  
g0 x-510 y-30 z-47  
g4 x-510 y-30 z-47 p2  
g0 x-510 y-30 z0
```

In this step, the gripper moves (g0) towards the axis x -510, y-30, which is just above the position of the first pattern of tasting. Then it moves towards the z-47 axis, doing stamping movements on batik cloth. This tapping motion is held (g4) for 2 seconds (p2). Then move (g0) to the previous direction, namely x-510, y-30, z0. Which then continued with the liquid wax immersion step.

4. Conclusion

Manual stamping testing or using this machine is done three times. Then the accuracy and precision of the stamping are compared as in Figure 3. The left-hand image with red ink is the result of manual stamping by batik craftsmen, and the right-hand result is stamping using CNC machines. It can be seen from the picture that stamping using CNC machines is more consistent and has better precision and accuracy than manual stamping.

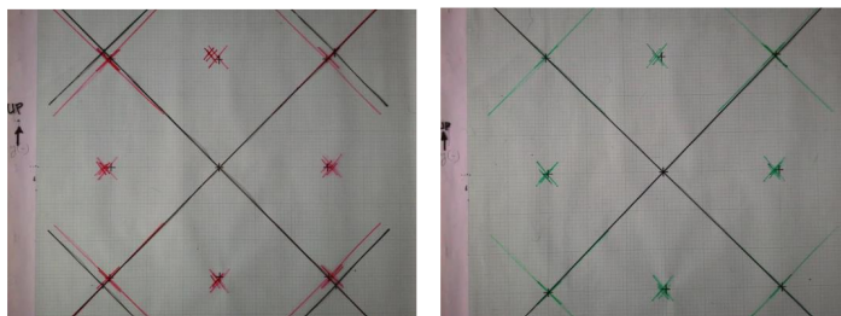

Figure 3. Comparison of accuracy and precision of craftsman manual stamping (red) vs. CNC machine stamping (green)

Although the thickness of the wax from the stamping results is not far adrift (average 0.003 mm) as shown in table 1, the manual stamping time is still 75 seconds faster than the stamping of CNC machines. Based on the results of the recommendations for the next research, it is necessary to do more in-depth research related to the trajectory and movement of the batik stamp to obtain a better stamping time without reducing the precision, accuracy, and thickness of the wax that has been achieved.

Table 1. The average thickness of the liquid wax as a result of the manual stamping of craftsmen vs. CNC machines

Measurement	1	2	3	4	average
Manual (mm)	0.547	0.312	0.448	0.492	0.450
Machine (mm)	0.472	0.412	0.374	0.555	0.453

Table 2. The average time of manual stamping of craftsmen vs. CNC machine stamping

Measurement	1	2	3	averages
Manual (second)	138	60	50	82,67
Machine (second)	158	158	157	157,67

References

- [1] Prasetyo, A., 2010, *Batik Karya Agung Warisan Budaya Dunia*, Penerbit Pura Pustaka
- [2] Hidayat, Y.A., 2012, *Efisiensi Produksi Kain Batik Cap*, Jurnal Ekonomi Pembangunan Volume 13, Nomor 1, Juni 2012, hlm.79-95 (<http://journals.ums.ac.id/index.php/JEP/article/view/184/171>)
- [3] Daliyo, Rahayu, S., Widodo, dan Y.B., Nagib, L., 2003, *Kualitas SDM era Otda dan Globalisasi; Kasus di Industri Perhotelan dan Kerajinan Batik di DIY*, Penerbit Sinar Harapan Jakarta
- [4] Wibisono, M.A. dan Toha, I.S., 2000, *Desain Batik Canting Cap Berbantuan Komputer*, Prosiding Seminar Nasional Proses Produksi, Universitas Atma Jaya Yogyakarta, Hal. 83-93
- [5] Ramelan, R., 2008, *Industri Batik dan Permasalahannya*, <http://cessee.com/2012/18/industri-batik-dan-permasalahannya.html> (accessed online on October 26, 2012)
- [6] Dwinugroho, T.B., dan Sudiarmo, A., 2015, *Penerapan Metode Quality Function Deployment (QFD) pada Perancangan Prototype Automatic Tool Changer dan Pengujiannya*, Prosiding Seminar Nasional Terpadu Keilmuan Teknik Industri, Universitas Brawijaya Malang
- [7] Wibisono, M.A., Wisudawan, C.G., Afriliana, E.H., dan Arbi, A., 2010, *Integrasi Proses Desain dan Manufaktur Batik Tulis*, Prosiding Seminar Nasional Tahunan Teknik Mesin IX, Palembang
- [8] Suroso, Wibisono, M.A., dan Rochardjo H.S.B., *Pengembangan Mesin Cetak Batik Cap Otomatis Berkendali Komputer Dengan Metode QFD.*, Prosiding Seminar Nasional VIII SDM Teknologi Nuklir, Yogyakarta
- [9] Venkata Ramesh M., Srinivasulu M and Mani Prasad N, 2016, *Study on Computer Numerical Control (CNC) Machines*, International Journal of Advanced Scientific Research, ISSN: 2456-0421 Volume 1; Issue 1; April 2016; Page No. 13-17 (www.newresearchjournal.com/scientific)
- [10] Primoz Kržič 1 - Antun Stoic2 - Janez Kopač 1, 2009, *STEP-NC: A New Programming Code for the CNC Machines*, Strojniški Vestnik - Journal of Mechanical Engineering 55(2009)6, 406-417, UDC 62
- [11] Groover, M. P., 2001, *Otomasi, Sistem Produksi, dan Computer-Integrated Manufacturing*, Penerbit Guna Widya Kertajaya 178 Surabaya
- [12] Perkasa, M.A.I., 2013, *Perancangan Proses Produksi Batik Cap Menggunakan Mesin CNC Batik*, Tesis S2 Teknik Industri UGM, Yogyakarta
- [13] Wibisono, M.A., Chandra, A.N., Dhaniel, F., dan Fitriana, Y., 2008, *Pengembangan Mesin Cap Batik Otomatis*, Prosiding Seminar Nasional Tahunan Teknik Mesin VII, Manado
- [14] Dwinugroho, T.B., *Implementasi Programmable Logic Control (PLC) pada Mesin Batik Cap Otomatis Berbasis CNC*, Industrial Engineering Journal of the University of Sarjanawiyata

Tamansiswa, Yogyakarta, ISSN: 2613-9812, Vol 1 No 1 (<http://jurnal.ustjogja.ac.id/index.php/IEJST/article/view/2038>)

- [15] Ulrich, K. T., Eppinger, S.D., 2001, *Perancangan dan Pengembangan Produk*, Penerbit Salemba Teknika, Grand Wijaya Center Bolk D-7, Jl. Wijaya 2, Jakarta, 12160

Design and Implementation of CNC Based Automatic Stamp Batik Machine

ORIGINALITY REPORT

20%

SIMILARITY INDEX

20%

INTERNET SOURCES

%

PUBLICATIONS

%

STUDENT PAPERS

PRIMARY SOURCES

1	iopscience.iop.org Internet Source	6%
2	digilib.unimed.ac.id Internet Source	4%
3	www.researchgate.net Internet Source	3%
4	orca.cf.ac.uk Internet Source	3%
5	www.ijert.org Internet Source	2%
6	jurnal.ustjogja.ac.id Internet Source	1%
7	www.abacademies.org Internet Source	1%

Exclude quotes On

Exclude bibliography On

Exclude matches < 1%

