

**KORESPONDENSI**  
**Journal of Economics and Management**

<b>Tanggal</b>	<b>Aktivitas</b>	<b>Keputusan</b>
05 Juni 2024	Submit manuskrip	
18 Juni 2024	Pemberitahuan dari Editor jika manuskrip dikirim ke reviewer	
18 Juli 2024	Pemberitahuan dari Editor jika manuskrip harus melakukan revisi major	Decision: Major revision
15 Agustus 2024	Mengirimkan hasil revisi ke jurnal	
17 September 2024	Pemberitahuan dari editor	Revisi minor
21 September 2024	Mengirimkan file revisi	
21 September 2024	Pemberitahuan dari editor	initially accepted for publication
23 September 2024	Pemberitahuan dari Editor in Chief	The English-language editor will now review your paper. After formatting and editing by the publishing editor, Mrs. Patricia Keller, the paper will be published. Both editors might contact you during this process to clarify any unclear wording or linguistic errors.
8 Oktober 2024	Revisi minor dari editor	requires technical and linguistic correction.
17 Oktober 2024	Article published	

1. 05 Juni 2024 Submitt manuskrip
2. 18 Juni 2024 Pemberitahuan dari Editor jika manuskrip dikirim ke reviewer

The paper has been sent to the Reviewers (JEM-00364-2024-01) X

Dear Dr. Sumarmi,

This is a general update regarding your paper: Authentic Leadership and Employee Silence Intention: Mediated by Perceptions of Organizational Politics and Organizational Commitment (JEM-00364-2024-01) which has been forwarded to the reviewers.

You will receive notifications via email regarding any further decisions concerning this paper.

Sincerely,  
Monika Eisenhardt, Managing Editor

-----  
Journal of Economics and Management  
University of Economics in Katowice, Poland  
e-mail: jem.submission@ue.katowice.pl  
website: <https://sciendo.com/journal/JEMUEKAT>; [www.ue.katowice.pl/jem/](http://www.ue.katowice.pl/jem/)

Editorial System is available here: <https://www.editorialsystem.com/jem/>

3. 18 Juli 2024 Pemberitahuan dari Editor jika manuskrip harus melakukan revisi major

Decision: **Major revision**

July 23, 2024  
JEM-00364-2024-01

Authentic Leadership and Employee Silence Intention: Mediated by Perceptions of Organizational Politics and Organizational Commitment

Dear Dr. Sumarmi,

Thank you for submitting your work titled Authentic Leadership and Employee Silence Intention: Mediated by Perceptions of Organizational Politics and Organizational Commitment to the Journal of Economics and Management (JEM). We are pleased to inform you that your paper has received positive reviews indicating the need for major revisions. To proceed with publication, it is essential that you thoroughly revise the paper following the enclosed reviews and comments from the Editor-in-Chief.

When revising your manuscript, please mark the changes using coloured text, as papers without coloured text will not be processed further. Additionally, please note that we cannot accept your paper until you provide a camera-ready copy, which should be proofread and free of punctuation, spelling, editorial, and grammatical errors.

For your convenience, you will need to submit two files:

1. The first document should contain your fully formatted revised paper, adhering to the specifications outlined in the "Requirements of Papers" section under the "For Authors" tab.

2. The second document is the Revisions Document, where you should provide a detailed, point-by-point explanation of how you have revised the submission in response to the comments from the reviewers and the Editor-in-Chief.

You can find a template for this document under the "JEM's Revisions Document" file on the "For Authors" tab [/https://www.ue.katowice.pl/en/units/journal-of-economics-and-management/for-authors.html/](https://www.ue.katowice.pl/en/units/journal-of-economics-and-management/for-authors.html/).

Please AVOID ENTERING ANY PERSONAL DATA into these documents. Revision deadline: 2024-08-18

Following your revisions, the paper will undergo another review, and a decision will be made regarding whether it requires additional revisions, is accepted, or is rejected.

For any additional questions, please get in touch with us at [jem.submission@ue.katowice.pl](mailto:jem.submission@ue.katowice.pl).

Once again, thank you for submitting your manuscript to JEM, and we look forward to receiving your revision.

Sincerely,  
Ewa Ziemba, Editor-in-Chief

-----

Journal of Economics and Management University of Economics in Katowice, Poland e-mail:

[jem.submission@ue.katowice.pl](mailto:jem.submission@ue.katowice.pl)

website: <https://sciendo.com/journal/JEMUEKAT>; [www.ue.katowice.pl/jem](http://www.ue.katowice.pl/jem)

Editor-in-Chief Comments:

- (1) Introduction: The introduction should provide a concise overview of the topic (max 2 pages), supported by the latest extensive international scientific literature. It is important to present the problem statement, highlight the research gap (motivation of the study), and clearly state the aim of the study. The aim stated in the abstract should align with the aim presented in the introduction. Additionally, the layout of the paper should be briefly outlined at the end of the introduction;
- (2) Model. The presentation of the theoretical model needs improvement. It does not look like a standard theoretical model. Figure 1 does not do a poor job of visualizing the model. It would be helpful to see all hypotheses represented appropriately and the positive/negative impact indicated;
- (3) Research methodology: The data collection dates must be indicated. The survey questionnaire should be added to the Appendix;
- (4) Sample and Data Collection: The flow of this section should be as follows: sampling method, sampling group, data collection (e.g., online method, dates of data collection, how respondents were invited, etc.), and respondents' profiles;
- (5) Discussion: The results of the hypotheses verification should be presented in the table;
- (6) All abbreviations must be explained before their first usage. For example, you use abbreviations in Figure 2, and they must be explained, e.g., in Table 1;
- (7) The CR value is usually written without points;
- (8) Decimal points. That there is a decimal point in English. Please verify all data in the text, tables, and figures; (9) Tables and Figures: Each table and each figure must be referenced from the text;

- (10) Please review JEM Guide for Authors, check and adjust the paper formatting. Some editorial errors have crept into the text of the paper, literature citations, enumerations, sections headings, tables/figures captions and references to them in the text, etc.;
- (11) Please ensure that the paper has been thoroughly reviewed for typographical and grammatical errors;
- (12) Please indicate in the Revisions Document, point by point, how you revised the submission in light of the reviewers and Editor-in-Chief's comments;

#### **Statistics evaluation Comments**

1. There is statement: "Our aim was to target 290 respondents, taking ten from each university." Please explain why only 10 respondents were selected from each university. Even if the sample does not meet the SRS criteria, weights can be used to select the number of respondents from each university to better represent the population.
2. In accordance with the previous point, please use numbers instead of mixed type number representations, i.e: "290" vs "ten".
3. Timeperiod of the study should be added.

#### **Final decision**

Minor Revision

#### **Review 1:**

Authentic Leadership and Employee Silence Intention: Mediated by Perceptions of Organizational Politics and Organizational Commitment

The reviewed paper concentrates on relationships between authentic leadership and employee silence intention mediated by perceptions of organizational politics and organizational commitment. The topic is interesting and important for modern organization however not very innovative since most of analyzed relationship have been the subject of previous studies. On the other hand, the author proposes an original, comprehensive model of relationships and intermediaries between authentic leadership and employee silence intention, what is valuable and worth of publishing. The strength of the paper is good theoretical basis – the conceptual framework is well grounded in theory, hypotheses are well developed and justified. Methodology is also fine and suitable for research problem formulated. Further empirical analyses are sufficient to solve the research problem.

In order to improve the value of the paper, I recommend only technical changes:

- 1) In the 'Introduction' section the aim of the paper should be announced and the structure of the paper should be shortly presented.
- 2) At the beginning of 'Introduction' (p. 3) Author refers to employees as 'a resource' for organizations. I recommend following the newer 'human capital' concept and refers to employees as 'capital' of organizations.
- 3) Fig. 1 (p. 9) should be announced in the text body. Moreover, it would be useful to indicate all hypotheses in this Figure for better understanding linkages between conceptual and research model of the paper.
- 4) The "PGRI" abbreviation (p. 9) should be explained and translated into English.
- 5) In 'Research Methodology' section there should be short justification why research was conducted in Universities
- 6) In the 'Measurements' section text descriptions should be added to Likert scale – what 1 and 5 means?

In the final conclusion I assess the reviewed paper positively and recommend it for publication in “Journal of Economics and Management” after improvements taking into account the comments made above.

#### **Review 2:**

I suggest the following amendments:

1. explain why the research sample is based on universities - organizations, and corporations are usually studied
2. if the sample is to be lecturers, the specificity of leadership at universities should be described as compared to companies, and corporations
3. in Figure 1 the hypotheses should be marked
4. in Figure 1, the descriptions should be unified - are they components or descriptors?
5. since universities are examined, conclusions should be narrowed to them and not to all organizations

#### **Review 3:**

Dear Author(s),

I find your paper interesting, however, there are very fundamental concerns which must be addressed.

1. Abstract- lines 19 to 20- Please rephrase the limitation. Why are the findings not generalizable? e.g. because of a small sample size or single industry focus?
2. Introduction- line 52- please place the references appropriately. e.g. Walumbwa et al (2008) defined authentic leadership as... Please check for this throughout your text
3. Line 82- please refer to my comments in 2. Also, consult journal specs.
4. Line 92- I suggest you remove – “the author delves”. Use a sentence that conveys your conceptual framing
5. Line 107, pls delete-‘the literature review’.
6. Lines 147, 157, 166, 197, please refer to my comments in 2
7. Under research methodology- lines 233 to 238- Your statement on purposive sampling should be rephrased. What do you mean by experienced individuals?
8. Line 238, what is acronym PGRI?
9. Line 239-Why did you target a sample size of 290? What is the basis? References required.
10. Line 246 to 251- please change ‘percent to %’.
11. Measurement section- lines 253 to 273. I am VERY concerned that you developed your constructs from single, outdated references. In my opinion, it is not acceptable for a paper in 2024.
12. In addition to my earlier comment, I am concerned about the representativeness of a single item for affective, continuance, and normative commitment. Pls provide reference support. The Use of Meyer et al (1993) alone is not adequate
13. Data analysis technique-line 279- pls remove “in contrast”. Are you comparing statistical methods?
14. Research findings section- Table 1-292 to 308- The items column does not communicate adequately to the reader. Pls use short clear sentences to describe the items
15. Lines 310 to 312- You have omitted a very important part of your results- DISCRIMINANT VALIDITY OF YOUR MODEL. This must be included.
16. Lines 328- Not making sense. Pls clarify

17. Lines 335 to 350- The use of sobel method for mediation analysis is outdated. AMOS makes provision for this analysis via the use of user-defined estimands. Pls consult your data analyst.
18. Discussion section- line 361. Pls delete-‘...so they dare...’ Use more professional language.
19. Lines 415 to 416. Pls clarify the 1st sentence.
20. Lines 424. Pls clarify the sentence starting from ‘...if, in an organisation....’

**Attachment**

[JEMReview3.docx](#)

**RESPONSE COMMENT**

**Editor-in-Chief Comments**

	Comments	Response to Editor-in-Chief Comments
(1)	Introduction: The introduction should provide a concise overview of the topic (max 2 pages), supported by the latest extensive international scientific literature. It is important to present the problem statement, highlight the research gap (motivation of the study), and clearly state the aim of the study. The aim stated in the abstract should align with the aim presented in the introduction. Additionally, the layout of the paper should be briefly outlined at the end of the introduction;	Thank you for your review and suggestions for presenting the Introduction. We have adjusted the Introduction following the tips of the editor-in-chief. We have also aligned the research objectives in the abstract and Introduction, as well as the layout of the paper.
(2)	Model. The presentation of the theoretical model needs improvement. It does not look like a standard theoretical model. Figure 1 does not do a poor job of visualizing the model. It would be helpful to see all hypotheses represented appropriately and the positive/negative impact indicated;	Thank you for your comments on the presentation of the study's theoretical model. We have refined the article and presented a visualization of the model by showing the research hypotheses.
(3)	Research methodology: The data collection dates must be indicated. The survey questionnaire should be added to the Appendix;	Thank you for your careful review. We have added the data collection date and survey questionnaire in the attachment.
(4)	Sample and Data Collection: The flow of this section should be as follows: sampling method, sampling group, data collection (e.g., online method, dates of data collection, how respondents were invited, etc.), and respondents' profiles;	Thank you for the explanation of the sampling and data collection flow. We have adjusted the flow of these sections to include the order of sampling methods, sampling groups, data collection (e.g., online process, data collection dates, how respondents were

		invited, etc.), and respondent profiles in the revised paper.
(5)	Discussion: The results of the hypotheses verification should be presented in the table;	Thank you for the writing suggestions in the Discussion, and the results of the hypothesis verification have been presented in the table;
(6)	All abbreviations must be explained before their first usage. For example, you use abbreviations in Figure 2, and they must be explained, e.g., in Table 1;	Thank you for suggesting that all abbreviations be explained before first use. We have corrected all abbreviations used in this paper.
(7)	The CR value is usually written without points;	Thank you for your feedback. We have written the CR Value without points.
(8)	Decimal points. That there is a decimal point in English. Please verify all data in the text, tables, and figures;	Thank you for your review. We have verified the decimal points in English, as well as all data in the text, tables, and figures;
(9)	Tables and Figures: Each table and each figure must be referenced from the text;	Thank you for your suggestion. And we have adjusted the tables and figures by referring to the text
(10)	Please review JEM Guide for Authors, check and adjust the paper formatting. Some editorial errors have crept into the text of the paper, literature citations, enumerations, sections headings, tables/figures captions and references to them in the text, etc.;	Thank you for your review. We have reviewed the JEM Guidelines and checked and adjusted the paper format to avoid editorial errors in the paper text, bibliography, enumeration, section headings, table/figure captions, and references.
(11)	Please ensure that the paper has been thoroughly reviewed for typographical and grammatical errors;	Thank you for your suggestions, and we have thoroughly revised this paper for typos and grammatical errors
(12)	Please indicate in the Revisions Document, point by point, how you revised the submission in light of the reviewers and Editor-in-Chief's comments;	Thank you for your suggestions. We have made corrections in the revised document, point by point, taking into account the comments of the reviewers and the editor-in-chief.

**Reviewer 1**

S/T	Reviewer Comments	Response to Reviewer Comments
	<p>The reviewed paper concentrates on relationships between authentic leadership and employee silence intention mediated by perceptions of organizational politics and organizational commitment. The topic is interesting and important for modern organization however not very innovative since most of analyzed relationship have been the subject of previous studies. On the other hand, the author proposes an original, comprehensive model of relationships and intermediaries between authentic leadership and employee silence intention, what is valuable and worth of publishing. The strength of the paper is good theoretical basis – the conceptual framework is well grounded in theory, hypotheses are well developed and justified. Methodology is also fine and suitable for research problem formulated. Further empirical analyses are sufficient to solve the research problem.</p>	<p>Thank you for your in-depth review. We are pleased to know that you think the theoretical basis in this manuscript is reasonable with its conceptual framework based on theory, well-developed and justified hypotheses, methodology, and empirical analysis to solve the research problem.</p>
1)	<p>In the ‘Introduction’ section the aim of the paper should be announced and the structure of the paper should be shortly presented.</p>	<p>Thank you for your review. The author has added the aim and structure of the paper to the revised manuscript.</p>
2)	<p>At the beginning of ‘Introduction’ (p. 3) Author refers to employees as ‘a resource’ for organizations. I recommend following the newer ‘human capital’ concept and refers to employees as ‘capital’ of organizations.</p>	<p>We appreciate your suggestion to follow the newer concept of ‘human resources’ and refer to employees as the ‘capital’ of the organization. We have adapted it as the proposed solution and are using those terms as they are.</p>
3)	<p>Fig. 1 (p. 9) should be announced in the text body. Moreover, it would be useful to indicate all hypotheses in this Figure for better understanding linkages between conceptual and research model of the paper.</p>	<p>Figure 1 (p. 9) should be announced in the body- text to show all the hypotheses and relationships between this paper's conceptual and research models. We will add information in the body text.</p>
4)	<p>The “PGRI” abbreviation (p. 9) should be explained and translated into English.</p>	<p>Thank you for your review. We have explained the abbreviation "PGRI" (p. 9) and translated it into English.</p>



S/T	Reviewer Comments	Response to Reviewer Comments
5)	In 'Research Methodology' section there should be short justification why research was conducted in Universities	Thank you for suggesting why research is conducted at the University. We have added an explanation in "Research Methodology" to the revised manuscript.
6)	In the 'Measurements' section text descriptions should be added to Likert scale – what 1 and 5 means?	Thank you for your thorough suggestions, and we have added a description of the Likert Scale used in this article.
	In the final conclusion I assess the reviewed paper positively and recommend it for publication in "Journal of Economics and Management" after improvements taking into account the comments made above.	We are grateful for the positive comments and recommendations for this article to be published in the "Journal of Economics and Management" after improvements considering reviewers' comments. This motivates us to continue producing research work in the future.

## Reviewer 2

S/T	Reviewer Comments	Response to Reviewer 2 Comments
1.	explain why the research sample is based on universities - organizations, and corporations are usually studied	Thank you for the thorough review. In the revised manuscript, we have added an explanation of the reasons why this research uses university organizations.
2.	if the sample is to be lecturers, the specificity of leadership at universities should be described as compared to companies, and corporations	Thank you for your careful review. We have added the specifics of leadership in universities and compared them to companies and corporations in the revision of the article.
3.	in Figure 1 the hypotheses should be marked	Thank you for the suggestion. In Figure 1, we

S/T	Reviewer Comments	Response to Reviewer 2 Comments
		marked the hypothesis in the revised paper.
4.	in Figure 1, the descriptions should be unified - are they components or descriptors?	Thank you for carefully reviewing our article; we have clarified the description in Figure 1.
5.	since universities are examined, conclusions should be narrowed to them and not to all organizations	Thank you for your suggestions and input on how to improve this paper. We have adjusted our conclusions by narrowing in on those universities.

### Reviewer 3

S/T	Reviewer Comments	Response to Reviewer 3 Comments
1.	Abstract- lines 19 to 20- Please rephrase the limitation. Why are the findings not generalizable? e.g. because of a small sample size or single industry focus?	Thank you for your review. We have paraphrased the abstract, lines 19 to 20, and explained why these findings cannot be generalized.
2.	Introduction- line 52- please place the references appropriately. e.g. Walumbwa et al (2008) defined authentic leadership as... Please check for this throughout your text	Thanks for the correction to place the reference correctly. We have checked the entire text to avoid the same mistakes.
3.	Line 82- please refer to my comments in 2. Also, consult journal specs.	Thank you for your review. We have corrected line 82 by referring to the reviewer's comments in section 2 and considering the journal specifications.
4.	Line 92- I suggest you remove – “the author delves”. Use a sentence that conveys your conceptual framing	Thank you for your review. We have corrected line 82 by referring to the reviewer's comments in section 2 and considering the journal specifications.
5.	Line 107, pls delete-“the literature review”.	Thanks for the suggestion. And we've removed Line 107 about the 'literature review.'
6.	Lines 147, 157, 166, 197, please refer to my comments in 2	Thank you for the correction; we have adjusted lines 147, 157, 166, 197, and comment 2.
7.	Under research methodology- lines 233 to 238- Your statement on purposive sampling should be rephrased. What do you mean by experienced individuals?	Thank you for the comprehensive review. We have corrected the statement on

S/ T	Reviewer Comments	Response to Reviewer 3 Comments
		lines 233 to 238-, expressed the statement about purposive sampling, and explained experienced people.
8.	Line 238, what is acronym PGRI?	Thank you for your input. PGRI is the abbreviation of the Persatuan Guru Republik Indonesia (in Indonesian), or in English, the Republic of Indonesia Teachers Association, and we have added it to the manuscript.
9.	Line 239-Why did you target a sample size of 290? What is the basis? References required.	Thank you for your review. We have added the sample size and basis for determining it.
10.	Line 246 to 251- please change 'percent to %'.	Thank you for your review. We have added the sample size and basis for determining it.
11.	Measurement section- lines 253 to 273. I am VERY concerned that you developed your constructs from single, outdated references. In my opinion, it is not acceptable for a paper in 2024.	Thank you for your review, and for the measurement section on lines 253 to 273, we have added references from other authors.
12.	In addition to my earlier comment, I am concerned about the representativeness of a single item for affective, continuance, and normative commitment. Pls provide reference support. The Use of Meyer et al (1993) alone is not adequate	Thank you for your thoughtful comments, and we have added reference support from other authors.
13.	Data analysis technique-line 279- pls remove "'in contrast'". Are you comparing statistical methods?	Thank you for the review. And we have removed the "otherwise" in the data analysis technique line 279.
14.	Research findings section- Table 1-292 to 308- The items column does not communicate adequately to the reader. Pls use short clear sentences to describe the items	Thank you for your review. We have used the sentence by replacing it with a statement item in the research results section - Tables 1-292 to 308.
15.	Lines 310 to 312- You have omitted a very important part of your results-DISCRIMNANT VALIDITY OF YOUR MODEL. This must be included.	Thank you for the review. We have added discriminant validity to the model in Lines 310 to 312
16.	Lines 328- Not making sense. Pls clarify	Thank you for your valuable input. We have used CB-SEM with AMOS to conduct the research data analysis, and the use of the Sobel test is no longer included in the manuscript.
17.	Lines 335 to 350- The use of sobel method for mediation analysis is outdated. AMOS makes provision for this analysis via the use of user-defined estimands. Pls consult your data analyst.	Thank you for your valuable input. We have used CB-SEM with AMOS to conduct the research data analysis, and the

S/ T	Reviewer Comments	Response to Reviewer 3 Comments
		use of the Sobel test is no longer included in the manuscript.
18.	Discussion section- line 361. Pls delete- '...so they dare...' Use more professional language.	Thank you for the suggestion in the discussion section- line 361. We have removed '...so they dare...' and used a more professional statement.
19.	Lines 415 to 416. Pls clarify the 1st sentence.	Thank you for your suggestions. In Lines 415 to 416, we have clarified the manuscript.
20.	Lines 424. Pls clarify the sentence starting from "...if, in an organisation...."	Thank you for the correction on Line 424. We have clarified the sentence starting from "...if, in an organization...." into a clearer sentence.

#### Statistical Editor:

		Response to Statistical Editor
1.	There is statement: "Our aim was to target 290 respondents, taking ten from each university." Please explain why only 10 respondents were selected from each university. Even if the sample does not meet the SRS criteria, weights can be used to select the number of respondents from each university to better represent the population.	Thank you for the comprehensive review. We have added an explanation of the number of respondents being 290, with ten from each university, and a theoretical reference to the reasons for selecting this sample size.
2.	In accordance with the previous point, please use numbers instead of mixed type number representations, i.e: "290" vs "ten".	Thank you for your input. We have adjusted the use of numbers instead of mixed type number representation, namely: "290" vs. "ten."
3.	Timeperiod of the study should be added.	Thank you for your suggestions on how to improve this manuscript. We have added a research period.

---

## Authentic Leadership and Employee Silence Intention: Mediated by Perceptions of Organizational Politics and Organizational Commitment

### Abstract

**Aim/Purpose** – This study examines authentic leadership's influence on employee silence intention, mediated by perceptions of organizational politics and organizational commitment.

**Design/methodology/approach** – Research data was obtained through a survey of 251 lecturers at PGRI universities. The method used to analyze the data was structural equation modeling with CB-SEM.

**Findings** – The research results show that authentic leadership, perceptions of organizational politics, and organizational commitment have a direct effect on employee silence intention. In addition, Perceptions of organizational politics and organizational commitment mediate the influence of authentic leadership on employee silence intention.

**Research implications/limitations** – The theoretical implications of this study strengthen the theory of authentic leadership by demonstrating its negative influence on employee silence intentions. However, a limitation of this study lies in the potential need for more generalizability of the findings, as the study focused only on higher education, so the results may not fully apply to different industries or cultural contexts.

**Originality/value/contribution** – This research makes a significant contribution by exploring the influence of authentic leadership on employee silence intention. It enriches the literature with empirical findings linking leadership honesty, openness, and transparency to reduced employee silence.

**Keywords:** authentic leadership, perceptions of organizational politics, organizational commitment, employee silence intention

**JEL Classification:** M12, M54, O15

### 1. Introduction

Employees' silence when discussing work-related matters has many consequences for individuals, teams, and organizations (Hao et al., 2022). This is because employees are capital with a central role in organizational activities to mobilize and synergize other resources to achieve predetermined goals. (Eckardt et al., 2021; Febriansyah et al., 2019). In the process of achieving performance, it is not uncommon for problems to arise from interactions between employees and colleagues, as well as employees and leaders. However, employees are reluctant to voice problems that arise in the workplace and tend to ignore these problems (Morrison, 2014). This condition is

triggered by a dilemma between considering the short-term interests of the leader, who may view voicing a problem as an act of disloyalty, and the organization's long-term interests, which may experience severe costs due to silence (Monzani et al., 2016).

Employee silence is not only related to problems between employees but also to expressing opinions, even though employees have a lot of knowledge and experience that can be used to improve organizational performance (Shaukat & Khurshid, 2022). Employee silence intention is a failure to convey important information to the authorities, which can cause problems for the organization (John & Manikandan, 2019). Previous studies on employee silence intention used this variable as a predictor, such as the impact on organizational turnover intention [Al Muala et al. \(2022\)](#), well-being, job attitude, and performance (Hao et al., 2022). Researchers intend to investigate employee silence intention as an outcome and use authentic leadership as a predictor.

*Authentic leadership* is defined [Walumbwa et al. \(2008\)](#) as a pattern of leadership behavior that explains and expands positive psychological abilities and a positive moral atmosphere to develop self-awareness, internal moral outlook, balanced information processing, and transparency of communication with followers. An authentic leader will positively affect organizational performance, and the positive impact of an authentic leader on team performance is more robust among employees with high social capital (Akhtar et al., 2021). The self-regulatory behavior inherent in the authentic leadership process shapes collective team behavior, which emerges in the process of team reflexivity, which in turn predicts team performance positively (Lyubovnikova et al., 2015). It is hoped that the leadership pattern of an authentic leader will reduce employee silence intention among employees. This is because authentic leaders can create a safe and trusting environment where team members can work effectively (Maximo et al., 2019). Studies conducted [Abdillah et al. \(2022\)](#); [Guenter et al. \(2017\)](#) found a negative relationship between authentic leadership and silent behavior. Meanwhile [Monzani et al., \(2016\)](#) use a form of silence behavior at the organizational level, namely Exit, Voice, Neglect, and Loyalty, and found a negative relationship between authentic leadership and exit and neglect. Meanwhile, authentic leadership, Loyalty, and Voice have a positive relationship.

In the social environment today, social politics is developing a lot in society and organizations, which is referred to as organizational politics (Sun & Xia, 2018). Differences in political perceptions in the organization that occur between employees, if not managed well, will have a negative impact on the organizational climate (Naseer et al., 2016). Perceptions of organizational politics refers to the maximization of personal interests by organizational members using methods that are not recognized by the formal rules of the organization to influence the distribution of benefits within the organization (Eldor, 2017; Kacmar & Baron, 1999). Research results show that the negative impact of perceptions of organizational politics in the workplace is exacerbated for employees with lower levels of honesty and humility (Wiltshire et al., 2014). [Buchanan \(2008\)](#), states that negative Perceptions of organizational politics can cause employees to feel insecure or worry about the consequences of expressing dissatisfaction. Employees who feel insecure or worried may be more likely to remain silent rather than risk coming forward (Behtoui et al., 2017). Authentic leadership brings transparency into decision-making so leaders can reduce misunderstandings (Alvesson & Einola, 2019). Additionally, transparency reduces the space for negative perceptions such as favoritism or hidden agendas, often related to office politics (Haavisto & Linge, 2022). As role models, authentic leaders demonstrate anti-political behavior (Fawcett & Corbett, 2018).

[Organizational commitment is a crucial link between authentic leadership and employees' silence intention.](#) Organizational commitment, a measure of the degree of employee involvement and participation in the organization [Sumarmi et al. \(2023\)](#), can be fostered by authentic leadership,

leading to a decrease in employee silence intention. Authentic leaders, as highlighted by [Maximo et al. \(2019\)](#), tend to exhibit consistent, predictive, and reliable behavior, which helps in building trust and psychological safety among employees. Employees who perceive high levels of honesty and transparency from their leaders are more likely to develop greater respect and dedication to the organization (Jiang & Luo, 2018). This commitment strengthens employee identification with the values and goals of the organization, thereby increasing organizational commitment (Nazir & Islam, 2017).

This paper aims to investigate the impact of authentic leadership on employees' intentions to be silent and to examine how authentic leadership can influence employees' willingness to voice concerns and opinions at work, considering the role of organizational commitment and perceptions of organizational politics.

The paper is structured as follows: after the introduction, a literature review is presented to provide a theoretical foundation. Following this, the methodology section outlines the research design and data collection methods. The results section presents the findings, which are then discussed in the context of the existing literature. Finally, the paper concludes with implications for practice, limitations of the study, and suggestions for future research.

## 2. Literature review

### 2.1. Authentic leadership and employee silence intention

This exploration will address the relationship between authentic leadership and two critical aspects of employee behavior and perceptions: employee silence intention and perceptions of organizational politics. Leaders who embody authentic leadership, emphasizing honesty, integrity, transparency, and authenticity in their interactions with subordinates [Jiang & Luo \(2018\)](#), create an environment where employees feel more comfortable and are encouraged to discuss the problems or concerns they face openly. This approach is expected to reduce the tendency to remain silent significantly (Kelly, 2023). Employee silence intention often stems from the perceptions that speaking openly is unsafe due to the fear of negative consequences or retaliation from management or co-workers (MacMahon et al., 2018). However, through strong, mutually beneficial relationships with subordinates, an authentic leader can foster an inclusive and supportive work environment. Therefore, robust, authentic leadership is anticipated to reduce employee silence in the organization, leading to a more positive and open workplace.

Based on this explanation, the first hypothesis is formulated as follows:

**H1:** Authentic leadership is negatively related to employee silence intention.

### 2.2. Authentic leadership and perceptions of organizational politics

Authentic leadership, characterized by honesty, consistency, and self-awareness, has a profound impact on employees' perceptions (Jiang & Luo, 2018). This leadership style, rooted in self-awareness and a deep understanding of values, strengths, and weaknesses, fosters a positive work environment (Rubens et al., 2018). Employees under the guidance of authentic leaders often develop more positive perceptions of fairness and transparency within the organization (Liu (2017), instilling a sense of hope and optimism in the workplace.

On the other hand, perceptions of organizational politics refer to employees' subjective views regarding the existence of political practices, nepotism, or manipulation of power within the organization (Jeong & Kim, 2022). This condition can cause employee job dissatisfaction because they feel unfair or unappreciated for their achievements or contributions. Organizational political practices can also damage trust between employees, management, and co-workers (Ullah et al., 2019). Authentic leadership emphasizing transparency, honesty, and self-awareness will reduce unethical political practices in organizations. Authentic leaders build a culture where decisions and promotions are based on performance and values, not internal politics or personal relationships.

Based on this explanation, the second hypothesis is formulated as follows:

**H2:** Authentic leadership is negatively related to perceptions of organizational politics.

### 2.3. Authentic leadership and organizational commitment

Avolio & Gardner (2005), Highlight the significant impact of authentic leadership in building trust and commitment among followers, where leaders who demonstrate honesty, integrity, and self-awareness can create an environment where employees feel valued and supported, leading to higher levels of commitment to the organization. Employees in an organization will develop a strong emotional attachment (affective commitment), perceive few costs associated with leaving the organization (continuance commitment), and feel a moral obligation to stay with the organization (normative commitment) (Ahmad, 2018; Palladan, 2018). Therefore, higher levels of authentic leadership are expected to result in higher levels of organizational commitment among employees.

The study Walumbwa et al. (2008) discovered a robust positive correlation between authentic leadership and followers' commitment to the organization. Further studies Hadian Nasab & Afshari, (2019); Ullah et al., (2019) have also confirmed this positive relationship. Drawing from these empirical findings, the third hypothesis is formulated as follows:

**H3:** Authentic leadership is positively related to organizational commitment.

### 2.4. Perceptions of organizational politics and employee silence intentions

Perceptions of organizational politics refers to employees' subjective perceptions of political behavior, favoritism, or manipulation of power within the organization (Khuwaja et al., 2020). Lam & Xu (2019), highlights the detrimental effects of perceived organizational politics on employee attitudes and behavior, where employees who perceive higher levels of organizational politics are more likely to experience job dissatisfaction, reduced organizational commitment, and higher stress



and turnover intentions. Higher. In addition, Ferris et al., (2007) conducted a meta-analysis that examined the relationship between perceptions of organizational politics and employee silence behavior and revealed a significant positive relationship between perceptions of organizational politics and employee silence intentions. Employees who perceive high levels of organizational politics may remain silent to avoid potential retaliation or ostracism from superiors or coworkers (Jahanzeb et al., 2018).

Perceptions of organizational politics create a work environment characterized by distrust, fear, and uncertainty among employees and trigger employees to remain silent and refrain from expressing their ideas, opinions, or concerns, even when doing so could benefit the organization. Studies Khalid & Ahmed (2016); Sun & Xia (2018), found a positive relationship between perceptions of organizational politics and employee silence. Based on this explanation, hypothesis 4 in this research is as follows.

**H4:** Perceptions of organizational politics are positively related to employee silence intention

## **2.5. Organizational commitment and employee silence intention**

Organizational commitment is employees' trust, involvement, and loyalty toward the organization (Sumarmi et al., 2022). This statement indicates that the higher a person's level of organizational commitment, the lower the possibility of showing behavior contrary to the organization's interests, such as remaining silent about potentially detrimental issues (Allen et al., 2017). The silence carried out by employees, including silence in conveying development opinions for the organization, tends to have a negative impact on the organization (Morrison, 2014). Employees who feel attached to the organization and have a high commitment to the organization tend not to remain silent about issues related to the welfare of the organization (Kim et al., 2023). The study Vardarlier & Akiner (2020) also found a negative relationship between organizational commitment and employee silence intention.

Based on the explanation above, the fifth hypothesis is as follows:

**H5:** Organizational commitment is negatively related to employee silence intention

## **2.6. The mediating effect of perceptions of organizational politics and organizational commitment**

Employees led by authentic leaders tend to have a more positive perceptions of organizational culture Koontz (2021), because it can create a supportive work environment where employees feel heard, appreciated, and encouraged to participate actively. In addition, an organizational culture influenced by authentic leadership will reduce employees' tendency to have political perceptions, thereby reducing employees' reticence to express opinions (Bakari et al., 2018). In an environment like this, employees feel safer to express opinions without fear of negative consequences.

Based on this explanation, the sixth hypothesis is as follows:

**H6:** Perceptions of organizational politics mediate the negative relationship between authentic leadership and employee silence intention.

Apart from the explanation above, the impact of authentic leaders is that employees become more identified with the values and goals of the organization so that they can increase their commitment to the organization (Ribeiro et al., 2019). This arises because leaders represent the values that employees believe in and support. Strong organizational commitment from employees will encourage employees to share information and relevant issues actively rather than remaining silent (Morrison, 2014). Based on this explanation, the seventh hypothesis is formulated as follows:

**H7:** Organizational commitment mediates the negative relationship between authentic leadership and employee silence intention.

The relationship between variables in the seven hypotheses above is presented in Figure 1. For each variable, indicators are also listed to measure the variable.

Figure 1. Research Model

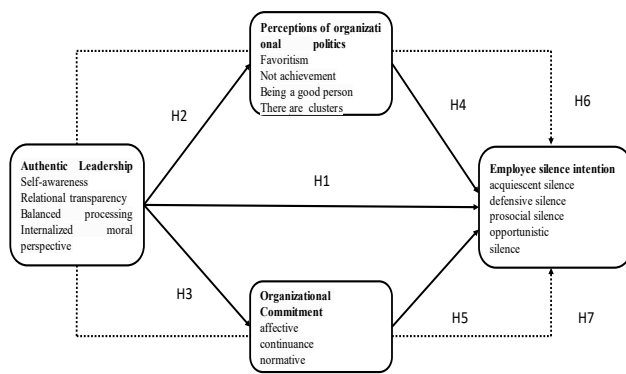

Source: Author's elaboration

### 3. Research methodology

#### 2.7. Sample and Data Collection

Our sampling method was distinct, utilizing a non-probability approach. This means that elements in the population were not uniformly likely to be selected as sample subjects. We employed a purposive sampling technique, a non-probability method where samples are selected based on specific characteristics deemed relevant by the researchers. This approach allows for the targeted selection of individuals who meet particular criteria essential for the study (Zikmund et al., 2010). In this study, we focused on 29 PGRI universities on the island of Java, Indonesia and 251 lecturers as respondents. PGRI is an abbreviation of "Persatuan Guru Republik Indonesia," or the Republic of Indonesia Teachers Association in English. The research was conducted at a university because academics have well-documented policies, and the unique pressures and politics at universities provide insight into how authentic leadership can reduce negative impacts on employee behavior, thereby increasing the generalizability of the findings to other contexts.

The population of this study was 1055 permanent lecturers of the PGRI foundation. Using the Slovin formula Yamane (1967)(Yamane, 1967), and calculations using the Slovin calculator and the formula above, the number of samples was 290,034.

$$n = \frac{N}{1+N(e)^2} \quad (1)$$

Description:

n = sample size/number of respondents

N = population size

e = percentage of tolerance for sampling error accuracy (Yamane, 1967).

$$n = \frac{1055}{1+1055(0,05)^2} \quad (2)$$

$$n = 290,034 \quad (3)$$

Since this study used 29 universities, the researchers took 10 respondents from each. Because this study used 29 universities, the researcher took 10 respondents from each. After waiting two months, respondents planned to fill out the questionnaire, but only 251 data could be analyzed.

Data collection was carried out using a questionnaire distributed through Google Forms. Before the respondents filled out the questionnaire, the researcher sent a message via personal network to the Vice Chancellor for Human Resource Development to assign lecturers to fill out the questionnaire. This research was conducted from March to May 2024. After waiting two months, the respondents planned to complete the questionnaire, but only 251 data could be analyzed. This research was conducted from March to May 2024. After waiting two months, the respondents planned to complete the questionnaire, but only 251 data could be analyzed. Lecturers who filled out the questionnaire had a gender distribution of 45,8 % female and 54,2 % male. The educational level of lecturers is 64,9 % have a Master's degree, and 35,1 have a Doctoral degree. Tenure of lecturers at universities < 5 years by 25,5 %; > 5 – 10 years by 35,5 %; > 10 – 15 years by 24,7 %; > 15 – 20 years by 11,9 %; and > 20 years by 2,4 %. Most lecturers' academic positions are Assistant Professor at 47,41 %, Associate Professor at 13.94 %, and Lecturer at 38.65 %.

## 2.8. Measurements

Authentic leadership, a key focus of our study, was measured using developed dimensions (Kelly, 2023; Ribeiro et al., 2020; Walumbwa et al., 2008). These dimensions include Self-awareness, Relational transparency, Balanced processing, and Internalized moral perspective. To provide a clear picture, we included examples of questionnaire items that reflect these dimensions, such as "Leaders always seek feedback to improve interactions with others" and "Leaders listen carefully and consider different points of view before concluding."

Leadership in higher education differs significantly from leadership in companies and corporations due to several unique factors. First, higher education has a more decentralized organizational structure with greater autonomy for each faculty and department (Frølich et al., 2019). This requires a leadership style that accommodates a diversity of opinions and a more collaborative approach. Authentic leadership is particularly relevant in this context because it emphasizes transparency, honesty, and integrity, which can build a safe and trusting environment for faculty to share their ideas and opinions without fear of reprisal (Maximo et al., 2019; Ribeiro et al., 2020). In addition, higher education has a dual mission of teaching, community service, and research that requires a flexible and supportive leadership approach (McCaffery, 2018). Authentic leadership can help create an academic culture that supports innovation and creativity by providing genuine support and recognition to faculty for their contributions (Alzghoul et al., 2018). In academic environments, where collaboration and professional development are highly valued, authentic leadership can increase faculty commitment to the institution and strengthen their involvement in decision-making processes (Elrehail et al., 2017). Finally, political pressures and dynamics in higher education often differ from those in companies and corporations (Ntim et al., 2017). Authentic

leadership that encourages open and honest communication can reduce negative perceptions of organizational politics and increase clarity and fairness in decision-making. Thus, authentic leadership in higher education promotes the psychological health and well-being of faculty and enhances the organization's effectiveness and performance as a whole.

Perception of organizational politics was measured using items developed Ferris & Kacmar (1992); Jeong & Kim (2022); Ullah et al. (2019), namely: Favoritism, not achievement, determines who is superior; you can get along here by being a good person, regardless of the quality of your work; and there are "clusters" or "clusters" that hinder effectiveness here.

Employee silence intention is measured using the dimensions of acquiescent silence, defensive silence, prosocial silence, and opportunistic (Hao et al., 2022; Harlos & Knoll, 2021). One item indicates the extent to which employees remain silent, such as "I prefer to remain silent rather than voice my opinion when faced with phenomena that affect work efficiency."

Organizational Commitment is measured using the dimensions of Nasab & Afshari (2019); Meyer et al., (1993), is affective, continuance, and normative. An example item is, "I feel proud to tell other parties that I am part of the PGRI organization."

The measurement scale for the four variables uses a Likert scale of 1 to 5. The measurement scale of the four variables uses a Likert scale of 1 to 5. For authentic leadership and organizational commitment, Scale 1 means Strongly disagree, Scale 2 disagree, Scale 3 neutral, Scale 4 agree, and Scale 5 means strongly agree. Perception of organizational politics and employee silence intention means the opposite, where scale 1 means Strongly agree, scale 2 agree, scale 3 neutral, Scale 4 disagree, and Scale 5 means strongly disagree.

## 2.9. Data analysis technique

Research data analysis began by testing the validity of the factorial structure, which was carried out through the use of confirmatory factor analysis (CFA) within a structural equation modeling (SEM) framework (Byrne, 2001). The hypothesis was tested using structural equation modeling, and the researcher used CB-SEM AMOS.

## 3. Research findings

The initial research stage was conducted by testing the instrument through reliability and construct validity. Based on the results of data analysis, the estimated Standardized Regression Weight value for all statement items is above 0,5, as presented in Table 1. This obtained value can be interpreted if all questionnaire items are declared valid. The reliability test can be determined from the CR and AVE values presented in Table 1. From the calculation results, the CR value is above 0,9, and the AVE value is above 0,5, so all questionnaire items are also declared reliable.

Table 1. Construct reliability and validity

Variable/constructs	items	Loading factors	Cronbach alpha	CR	AVE
Authentic_Leadership	Leaders at our college accurately describe	,721	0,910		

	how others view their abilities.				
	Leaders always seek feedback to improve interactions with others.	,915		0,91	0,71
	Leaders at our colleges demonstrate beliefs consistent with action.	,911			
	Leaders listen carefully and consider different points of view before concluding.	,853			
Perceptions of Organizational Politics	The deciding factor for winning here is not merit, but rather favoritism.	,705	0,919	0,91	0,71
	Leaders in these organizations frequently employ selection procedures to exclusively recruit individuals who can offer assistance in the future or share similar perspectives.	,907			
	Success depends on knowing the right people and seeking their help when needed.	,921			
	There are always influential groups in these organizations due to gender, regionalism, school ties, and kinship.	,816			
Organizational Commitment	I stay with this organization because I value loyalty and feel a moral obligation to remain.	,814	0,902	0,92	0,8
	I feel proud to tell other parties that I am part of the PGRI organization.	,948			
	I am eager to commit to a long and successful career with this organization.	,916			
Employee Silence Retention	I believe it might be unsafe to voice my concerns.	,952	0,899	0,89	0,69
	I was concerned that sharing my thoughts and concerns could have a detrimental effect on my professional advancement.	,942			
	To deliberately inflict harm on another individual.	,711			
	I think expressing my thoughts and worries could potentially hinder my career progression.	,677			

Source: processed primary data (2024)

The HTMT criterion for discriminant validity of first-order constructs, as suggested by (Hair et al., 2017), should not surpass 0,9. In the pairwise comparisons presented in Table 3, the HTMT value did not go beyond 0,9, thus confirming discriminant validity.

**Table 2. Discriminant validity Heterotrait – monotrait rasion (HTMT) results**

Constructs	Authentic leadership	Organizational commitment	employee silence intention
Authentic leadership			
Organizational committment	0,792		
employee silence intention	0,841	0,893	
perceptions of organizational politics	0,826	0,810	0,851

Source: processed primary data (2024)

After all statement items are declared valid and reliable, a full research model analysis is carried out to test the hypothesis. The results of the hypothesis testing are presented in Figure 2, Table 3, and Table 4.

**Figure 2: Full Model Analysis**

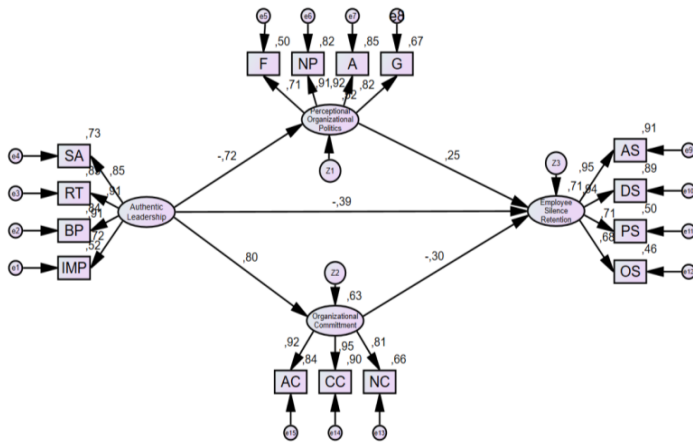

Note: SA: Self awareness, RT: Relational transparency, BP: Balance processing, IMP: Internalized moral perspective; F: Favoritism; NP: Not achievement; G: Being a Good person' A:there a clusters; AC: Affective commitment, CC: Continuance Commitment, NC: Normative commitment; AS: acquiescent silence, DS: defensive silence, PS: prosocial silence, and OS: opportunistic silence.

Based on the data analysis results in Table 3, the p-value obtained from the direct relationship between the variables tested in hypotheses 1 – 5 is 0,000, with a statistical t-value greater than 1,96. These results show that the direct influence on hypotheses 1 – 5 is proven to be significant, so this hypothesis is supported by the research results.

**Table 3. Direct Effect Hypothesis Test Results**

Direct effect	Estimate	S.E.	CR	P	Decision
---------------	----------	------	----	---	----------

Authentic_Leadership and Perceptions_Organizational_Politics	-,833	,085	9,755	***	Supported
Authentic_Leadership and Organizational_Committment	,840	,080	10,469	***	Supported
Perceptions_Organizational_Politics and Employee_Silence_Retention	,229	,079	2,902	.004	Supported
Organizational_Committment and Employee_Silence_Retention	-,295	,131	2,248	.025	Supported
Authentic_Leadership and Employee_Silence_Retention	-,407	,134	3,028	.003	Supported

Source: processed primary data (2024)

Table 4 shows the output of the indirect effect analysis, where perceptions of organizational politics and organizational commitment mediate the influence of authentic leadership and employee silence intention. The p-value of the indirect relationship between authentic leadership and employee silence intention is 0,000, with a t-statistic value greater than 1,96. Likewise, the p-value of authentic leadership and employee silence intention is mediated by organizational commitment. These results indicate that the indirect effect on hypotheses 6 and 7 is significant, so the study's results support this hypothesis.

Table 4. Indirect Effect Hypothesis Test Results

Indirect effect	Estimate	S.E.	CR	P	Decision
Perceptions of organizational politics mediate authentic leadership and employee silence intention.	-,190	,068	2,815	0,005	Supported
Organizational commitment mediates authentic leadership and employee silence intention.	-0,247	,116	2,133	0,033	Supported

Source: processed primary data (2024)

## 5. Discussion

The finding of the first hypothesis, where authentic leadership negatively influences employee silence intention, adds to the empirical findings of studies conducted (Abdillah et al., 2022; Guenter et al., 2017; Monzani et al., 2016). Based on the study findings, authentic leadership is necessary for creating a positive and productive work environment through openness, trust, and involvement, reducing employees' tendency to remain silent and encouraging more significant contributions from all team members. When employees perceive their leaders as honest and transparent, trust in them increases, reducing their apprehension about potential negative consequences when expressing their opinions (Agote et al., 2016). Employees are likelier to speak up and participate actively in discussions and decision-making. These conditions not only improve the organization's overall health but also encourage innovation and continuous improvement.

The second hypothesis is also supported by research results, where Authentic Leadership also negatively influences Perception of Organizational Politics. Authentic leaders consistently behave honestly and openly, which helps reduce suspicion and perceptions of manipulation among employees (Alvesson & Einola, 2019). When employees see that their leaders operate with integrity, their trust in the organization increases, and perceptions of organizational politics decrease (Lampaki & Papadakis, 2018). Authentic leaders also ensure that decisions are made based on fair and transparent principles, not favoritism or hidden agendas, which helps reduce the perception that political actions dominate the organization. Employees are encouraged to convey their ideas, input, and concerns without fear of reprisal or manipulation. They will create a culture where every voice is



valued and considered, reducing perceptions of organizational politics (Alavi & Gill, 2016). Employee engagement increases when they feel valued and heard. Authentic leadership will help create an environment where employees feel motivated to contribute positively without getting involved in organizational politics to get ahead.

This study also proves the third hypothesis that authentic leadership positively affects organizational commitment. This study is in line with the findings of Tijani & Okunbanjo (2020), which also found a positive influence between these two variables. Honesty and transparency, emphasized in authentic leadership, will build trust between leaders and employees. When employees believe that their leaders are honest and consistent, it will create a greater sense of psychological security Maximo et al. (2019), and this sense of security increases employees' emotional attachment (affective commitment) to the organization (Camgoz & Karapinar, 2016). Authentic leaders encourage employees to participate actively in the decision-making process and share ideas and input so that employees feel valued. A sense of appreciation makes employees more emotionally and normatively committed to the organization (Morrison, 2014).

The fourth hypothesis is also substantiated by the research, revealing that Perceptions of Organizational Politics has a detrimental effect on employee silence intention. The high perception of organizational politics among employees often instills fear of negative consequences if they voice their opinions (Morrison, 2014). Employees are concerned that expressing their views could jeopardize their position, influence performance evaluations, or make them vulnerable to retaliation by powerful individuals within the organization (Bashshur & Oc, 2015; Brinsfield, 2012). This situation breeds apathy and a reluctance to be actively involved, leading employees to choose silence. They withdraw and opt not to voice their opinions, believing that it will not positively impact their future careers.

The fifth hypothesis produces the finding that organizational commitment negatively influences employee silence intention. Employees with high commitment to the organization are emotionally attached to the organization. This attachment creates a sense of ownership and responsibility to contribute positively. It is happy to voice opinions based on concern for the success and welfare of the organization (Kim & Beehr, 2018). Employees feel that employee voices are essential for organizational development and will be heard, so they tend to reduce their intention to remain silent (Ruck et al., 2017). Moreover, with high commitment, employees have a greater sense of trust in the organization and its leaders. Employees feel safe to express their opinions without fear of negative consequences.

The study's results also support the test of the indirect effect of authentic leadership on employee silence intention mediated by dynamic adaptive capability and authentic leadership on employee silence intention mediated by organizational commitment. Perception of organizational politics is proven to mediate the negative influence of authentic leadership on employee silence intention. The findings highlight the complexity of organizational dynamics. Honest and open leaders tend to create a work environment where employees feel safe and can voice opinions without fear of negative repercussions (Jha & Singh, 2019). This honesty and openness directly reduce employee intentions to remain silent. However, authentic leadership is essential, and reducing perceptions of politics within the organization is crucial in encouraging open communication and reducing employee intentions to remain silent (Kim et al., 2023). Even in organizations with authentic leadership, employees may remain hesitant to voice their opinions if they perceive a high level of organizational politics. It is based on the idea that open communication will not be protected or valued in an environment

dominated by organizational politics. Therefore, organizations must work proactively to create a transparent, fair, and supportive work environment to achieve these goals (Chang et al., 2022).

The finding that organizational commitment mediates the negative influence of authentic leadership on employees' intention to remain silent underscores the importance of fostering strong and committed relationships between employees and the organization. This finding reiterates the main message of the research, which is that authentic leadership not only promotes openness and trust in the workplace but also strengthens employee commitment, thereby reducing their tendency to remain silent. The research suggests that organizations should focus on developing authentic leadership and commitment-enhancing strategies to create a more open and productive work environment. This, in turn, encourages employees to speak up and share their ideas for the benefit of the organization, thereby reinforcing the importance of the research findings.

## 6. Conclusions

This study confirms that authentic leadership hurts employees' intention to remain silent, and perceptions of organizational politics and organizational commitment mediate this effect. Authentic leadership characterized by honesty, openness, and transparency can create a more positive, productive, and politically free work environment, reducing employees' tendency to remain silent. In addition, employees who feel valued and trust their leaders tend to be more committed to the university and are more courageous in voicing their opinions.

The theoretical implications of this research strengthen authentic leadership theory by adding empirical evidence about its negative influence on employee intentions to remain silent. This implication shows that authentic leadership influences employee performance and well-being and plays an essential role in reducing employee silence. It also adds to the literature on organizational politics by showing that authentic leadership can reduce perceptions of organizational politics, reducing employee intentions to remain silent. This study expands the understanding of how organizational commitment mediates the relationship between authentic leadership and employees' silence intention to remain silent, suggesting that increasing employee commitment can play an essential role in creating a more open and collaborative work environment.

The practical implications of this study are clear: Universities should prioritize leadership development through training programs emphasizing honesty, transparency, and openness. Additionally, management should actively seek to reduce organizational politics by implementing fair and transparent policies and avoiding favoritism. These steps are crucial to creating a healthier and more open work environment.

It is essential to note the limitations of this study. The findings, while significant, may only be universally applicable to some industries or cultures. Therefore, further research is needed to validate the findings in different contexts, ensuring the robustness and reliability of the study's conclusions.

Suggestions for future research include contextual studies. Conducting research across industries and cultures can strengthen the generalizability of these findings and help understand how context influences these relationships. Further research could explore additional mediator or moderator variables that may influence these relationships, such as organizational culture, psychological climate, and communication style.

### 7. Declaration of competing interest

The author declares that there is no potential conflict of interest.

### 8. Funding

The research was supported by xxxxxxxxx (should be added after review)

## Appendix A

**Table 5.** Questionnaire

Variable	Item
Authentic_Leadership	Leaders at our college accurately describe how others view their abilities.
	Leaders always seek feedback to improve interactions with others
	Leaders at our colleges demonstrate beliefs consistent with action.
	Leaders listen carefully and consider different points of view before concluding
Perceptions of Organizational Politics	The deciding factor for winning here is not merit, but rather favoritism.
	Leaders in these organizations frequently employ selection procedures to exclusively recruit individuals who can offer assistance in the future or share similar perspectives.
	Success depends on knowing the right people and seeking their help when needed.
	There are always influential groups in these organizations due to gender, regionalism, school ties, and kinship.
Organizational Commitment	I stay with this organization because I value loyalty and feel a moral obligation to remain.
	I feel proud to tell other parties that I am part of the PGRI organization
	I am eager to commit to a long and successful career with this organization.
Employee Silence Retention	I believe it might be unsafe to voice my concerns.
	I was concerned that sharing my thoughts and concerns could have a detrimental effect on my professional advancement.
	To deliberately inflict harm on another individual.
	I think expressing my thoughts and worries could potentially hinder my career progression.

## References

- Abdillah, M. R., Anita, R., Agusanto, A., & Rahmat, A. (2022). Authentic Leader and Employee's Silence Behavior: Testing a Happiness at Work Mechanism. *INOBIIS: Jurnal Inovasi Bisnis Dan Manajemen Indonesia*, 5(4), 443–460. <https://doi.org/10.31842/jurnalnobis.v5i4.243>
- Agote, L., Aramburu, N., & Lines, R. (2016). Authentic Leadership Perception, Trust in the Leader, and Followers' Emotions in Organizational Change Processes. *Journal of Applied Behavioral Science*, 52(1), 35–63. <https://doi.org/10.1177/0021886315617531>
- Ahmad, A. (2018). The relationship among job characteristics organizational commitment and employee turnover intentions: A reciprocation perspective. *Journal of Work-Applied Management*, 10(1), 74–92. <https://doi.org/10.1108/JWAM-09-2017-0027>

- Akhtar, M. W., Aslam, M. K., Huo, C., Akbar, M., Afzal, M. U., & Rafiq, M. H. (2021). The interplay of authentic leadership and social capital on team leader performance in public and private sector universities. *Kybernetes*, 1. <https://doi.org/10.1108/K-06-2021-0446>
- Al Muala, I., Al-Ghalabi, R. R., Alsheikh, G. A. A., Hamdan, K. B., & Alnawafleh, E. A. T. (2022). Evaluating the Effect of Organizational Justice on Turnover Intention in the Public Hospitals of Jordan: Mediated-Moderated Model of Employee Silence, Workplace Bullying, and Work Stress. *International Journal of Professional Business Review*, 7(3), 1–23. <https://doi.org/10.26668/businessreview/2022.v7i3.0526>
- Alavi, S. B., & Gill, C. (2016). Leading Change Authentically : How Authentic Leaders Influence Follower Responses to Complex Change. *Journal of Leadership & Organizational Studies*, 24(2), 1–15. <https://doi.org/10.1177/1548051816664681>
- Allen, D. G., Pelkotorpi, V., & Rubenstein, A. L. (2017). When “embedded” means “stuck” : moderating effects of job embeddedness in adverse work environments. *Journal of Applied Psychology*, 101(2016), 1670–1686.
- Alvesson, M., & Einola, K. (2019). Warning for excessive positivity: Authentic leadership and other traps in leadership studies. *Leadership Quarterly*, 30(4), 383–395. <https://doi.org/10.1016/j.leaqua.2019.04.001>
- Alzghoul, A., Elrehail, H., Emeagwali, O. L., & AlShboul, M. K. (2018). Knowledge management, workplace climate, creativity and performance: The role of authentic leadership. *Journal of Workplace Learning*, 30(8), 592–612. <https://doi.org/10.1108/JWL-12-2017-0111>
- Avolio, B. J., & Gardner, W. L. (2005). Authentic leadership development: Getting to the root of positive forms of leadership. *Leadership Quarterly*, 16(3), 315–338. <https://doi.org/10.1016/j.leaqua.2005.03.001>
- Bakari, H., Hunjra, A. I., Shabbir, G., & Niazi, K. (2018). How Does Authentic Leadership Influence Planned Organizational Change ? The Role of Employees ' Perceptions : Integration of Theory of Planned Behavior and Lewin ' s Three Step Model. *Journal of Change Management*, 17(2), 1–33. <https://doi.org/10.1080/14697017.2017.1299370>
- Bashshur, M. R., & Oc, B. (2015). When Voice Matters: A Multilevel Review of the Impact of Voice in Organizations. *Journal of Management*, 41(5), 1530–1554. <https://doi.org/10.1177/0149206314558302>
- Behtoui, A., Boréus, K., Neergaard, A., & Yazdanpanah, S. (2017). Speaking up, leaving or keeping silent: Racialized employees in the Swedish elderly care sector. *Work, Employment and Society*, 31(6), 954–971. <https://doi.org/10.1177/0950017016667042>
- Brinsfield, C. T. (2012). Employee silence Motives: Investigation of diemnsionality and development of measures. *Journal of Organizational Behavior*, 60(1), 5–22. <https://doi.org/10.1002/job.1829>
- Buchanan, D. A. (2008). You stab my back, I'll stab yours: Management experience and perceptions of organization political behaviour. *British Journal of Management*, 19(1), 49–64. <https://doi.org/10.1111/j.1467-8551.2007.00533.x>
- Byrne, B. M. (2001). Structural Equation Modeling With AMOS , EQS , and LISREL : Comparative Approaches to Testing for the Factorial Validity of a Measuring Instrument. *International Journal of Testing*, 1(1), 55–86.
- Camgoz, S. M., & Karapinar, P. B. (2016). Linking secure attachment to commitment: trust in supervisors. *Leadership & Organization Development Journal*, 34(1), 1–5.
- Chang, P. C., Ma, G., & Lin, Y. Y. (2022). Inclusive Leadership and Employee Proactive Behavior: A Cross-Level Moderated Mediation Model. *Psychology Research and Behavior Management*, 15, 1797–1808. <https://doi.org/10.2147/PRBM.S363434>
- Eckardt, R., Tsai, C. Y., Dionne, S. D., Dunne, D., Spain, S. M., Park, J. W., Cheong, M., Kim, J., Guo, J., Hao, C., & Kim, E. II. (2021). Human capital resource emergence and leadership. *Journal of Organizational Behavior*, 42(2), 269–295. <https://doi.org/10.1002/job.2446>
- Eldor, L. (2017). Looking on the Bright Side: The Positive Role of Organisational Politics in the Relationship between Employee Engagement and Performance at Work. *Applied Psychology*, 66(2), 233–259. <https://doi.org/10.1111/apps.12090>
- Elrehail, H., Emeagwali, O. L., Alsaad, A., & Alzghoul, A. (2017). The Impact of Transformational and Authentic Leadership on Innovation in Higher Education : The Contingent Role of Knowledge Sharing. *Telematics and Informatics*. <https://doi.org/10.1016/j.tele.2017.09.018>

- Fawcett, P., & Corbett, J. (2018). Politicians, professionalization and anti-politics: why we want leaders who act like professionals but are paid like amateurs. *Policy Sciences*, 51(4), 411–432. <https://doi.org/10.1007/s11077-018-9323-7>
- Febriansyah, Sumarmi, S., & Haryono, S. (2019). Pengaruh Kepemimpinan, Kemampuan Kerja Terhadap Kinerja Pegawai Dinas Pendidikan Provinsi Sumsel Dimediasi Motivasi Kerja. *Jurnal Ekonomi Manajemen Sumber Daya*, 22(1), 21–28. <https://journals.ums.ac.id/index.php/dayasaing/article/view/10704>
- Ferris, G. R., & Kacmar, K. M. (1992). Perceptions of Organizational Politics. *Journal of Management*, 18(1), 93–116.
- Ferris, G. R., Treadway, D. C., Perrewé, P. L., Brouer, R. L., Douglas, C., & Lux, S. (2007). Political skill in organizations. *Journal of Management*, 33(3), 290–320. <https://doi.org/10.1177/0149206307300813>
- Frølich, N., Christensen, T., & Stensaker, B. (2019). Strengthening the strategic capacity of public universities: The role of internal governance models. *Public Policy and Administration*, 34(4), 475–493. <https://doi.org/10.1177/0952076718762041>
- Guenter, H., Schreurs, B., van Emmerik, I. H., & Sun, S. (2017). What Does it Take to Break the Silence in Teams: Authentic Leadership and/or Proactive Followership? *Applied Psychology*, 66(1), 49–77. <https://doi.org/10.1111/apps.12076>
- Haavisto, V. E., & Linge, T. T. (2022). Internal crisis communication and Nordic leadership: the importance of transparent and participative communication in times of crisis. *Scandinavian Journal of Hospitality and Tourism*, 22(4–5), 331–356. <https://doi.org/10.1080/15022250.2022.2123038>
- Hadian Nasab, A., & Afshari, L. (2019). Authentic leadership and employee performance: mediating role of organizational commitment. *Leadership and Organization Development Journal*, 40(5), 548–560. <https://doi.org/10.1108/LODJ-01-2019-0026>
- Hair, J. F., Matthews, L. M., Matthews, R. L., & Sarstedt, M. (2017). PLS-SEM or CB-SEM: Updated guidelines on which method to use. *International Journal of Multivariate Data Analysis*, 1(2), 107.
- Hao, L., Zhu, H., He, Y., Duan, J., Zhao, T., & Meng, H. (2022). When Is Silence Golden? A Meta-analysis on Antecedents and Outcomes of Employee Silence. *Journal of Business and Psychology*, 37(5), 1039–1063. <https://doi.org/10.1007/s10869-021-09788-7>
- Harlos, K., & Knoll, M. (2021). Employee Silence and Workplace Bullying. In *Pathways of Job-related Negative Behaviour. Handbooks of Workplace Bullying, Emotional Abuse and Harassment* (2nd ed.). [https://doi.org/https://doi.org/10.1007/978-981-13-0935-9\\_9](https://doi.org/https://doi.org/10.1007/978-981-13-0935-9_9)
- Jahanzeb, S., Fatima, T., & Malik, M. A. R. (2018). Supervisor ostracism and defensive silence: a differential needs approach. *European Journal of Work and Organizational Psychology*, 27(4), 430–440. <https://doi.org/10.1080/1359432X.2018.1465411>
- Jeong, Y., & Kim, M. (2022). Effects of perceived organizational support and perceived organizational politics on organizational performance: Mediating role of differential treatment. *Asia Pacific Management Review*, 27(3), 190–199. <https://doi.org/10.1016/j.apmr.2021.08.002>
- Jha, J. K., & Singh, M. (2019). Exploring the mechanisms of influence of ethical leadership on employment relations. In *IIMB Management Review* (Vol. 31, Issue 4). Elsevier Ltd. <https://doi.org/10.1016/j.iimb.2019.07.010>
- Jiang, H., & Luo, Y. (2018). Article information : Crafting Employee Trust : From Authenticity , Transparency to Engagement. *Journal of Communication Management*, 22(2), 138-160. <https://doi.org/https://doi.org/10.1108/JCOM-07-2016-0055>
- John, S. P., & Manikandan, K. (2019). Employee Silence : A Meta-Analytic Review. *The International Journal of Indian Psychology*, 7(1), 354–366. <https://doi.org/10.25215/0701.040>
- Kacmar, K. M., & Baron, R. A. (1999). Organizational politics: the state of the field, links to related processes. *Personnel and Human Resources Management*, 17(August), 1–39.
- Kelly, L. (2023). Authentic Leadership: Roots of the Construct. In *Mindfulness for Authentic Leadership* (Issue November, pp. 17–52). [https://doi.org/10.1007/978-3-031-34677-4\\_2](https://doi.org/10.1007/978-3-031-34677-4_2)
- Khalid, J., & Ahmed, J. (2016). Perceived organizational politics and employee silence: supervisor trust as a

- moderator. *Journal of the Asia Pacific Economy*, 21(2), 174–195.  
<https://doi.org/10.1080/13547860.2015.1092279>
- Khuwaja, U., Ahmed, K., Abid, G., & Adeel, A. (2020). Leadership and employee attitudes: The mediating role of perception of organizational politics. *Cogent Business and Management*, 7(1).  
<https://doi.org/10.1080/23311975.2020.1720066>
- Kim, M., & Beehr, T. A. (2018). Organization-Based Self-Esteem and Meaningful Work Mediate Effects of Empowering Leadership on Employee Behaviors and Well-Being. *Journal of Leadership and Organizational Studies*, 25(4), 385–398. <https://doi.org/10.1177/1548051818762337>
- Kim, Y., Lee, E., Kang, M., & Yang, S. U. (2023). Understanding the Influence of Authentic Leadership and Employee-Organization Relationships on Employee Voice Behaviors in Response to Dissatisfying Events at Work. In *Management Communication Quarterly* (Vol. 37, Issue 1).  
<https://doi.org/10.1177/08933189221085562>
- Koontz, K. (2021). *A Quantitative Study Measuring Organizational Culture Perception in Regard to Authentic Followership* (Issue August).
- Lam, L. W., & Xu, A. J. (2019). Power Imbalance and Employee Silence: The Role of Abusive Leadership, Power Distance Orientation, and Perceived Organisational Politics. *Applied Psychology*, 68(3), 513–546.  
<https://doi.org/10.1111/apps.12170>
- Lampaki, A., & Papadakis, V. (2018). The impact of organisational politics and trust in the top management team on strategic decision implementation success: A middle-manager's perspective. *European Management Journal*, 36(5), 627–637. <https://doi.org/10.1016/j.emj.2018.07.005>
- Liu, M. (2017). Study on Influence Mechanism of Leader-member Exchange Differences to Team Performance. *Proceedings of the 2016 2nd International Conference on Economy, Management, Law and Education (EMLE 2016)*, 20(Emle 2016), 223–227. <https://doi.org/10.2991/emle-16.2017.51>
- Lyubovnikova, J., Legood, A., Turner, N., & Mamakouka, A. (2015). How Authentic Leadership Influences Team Performance: The Mediating Role of Team Reflexivity. *Journal of Business Ethics*, 23(4), 307.  
<https://doi.org/10.3176/chem.geol.1974.4.04>
- MacMahon, J., O'Sullivan, M., Murphy, C., Ryan, L., & MacCurtain, S. (2018). Speaking up or staying silent in bullying situations: the significance of management control. *Industrial Relations Journal*, 49(5–6), 473–491. <https://doi.org/10.1111/irj.12230>
- Maximo, N., Stander, M. W., & Coxen, L. (2019). Authentic leadership and work engagement: The indirect effects of psychological safety and trust in supervisors. *SA Journal of Industrial Psychology*, 45, 1–11.  
<https://doi.org/10.4102/sajip.v45i0.1612>
- McCaffery, P. (2018). The Higher Education Manager's Handbook: Effective Leadership and Management in Universities and Colleges: Third edition. In *The Higher Education Manager's Handbook: Effective Leadership and Management in Universities and Colleges: Third edition* (Issue September).  
<https://doi.org/10.4324/9781351249744>
- Meyer, J. P., Allen, N. J., & Smith, C. A. (1993). Commitment to Organizations and Occupations: Extension and Test of a Three-Component Conceptualization. *Journal of Applied Psychology*, 78(4), 538–551.  
<https://doi.org/10.1037/0021-9010.78.4.538>
- Monzani, L., Braun, S., & van Dick, R. (2016). It takes two to tango: The interactive effect of authentic leadership and organizational identification on employee silence intentions. *German Journal of Human Resource Management*, 30(3–4), 246–266. <https://doi.org/10.1177/2397002216649896>
- Morrison, E. W. (2014). Employee Voice and Silence. *Annual Review of Organizational Psychology and Organizational Behavior*, 1, 173–197. <https://doi.org/10.1146/annurev-orgpsych-031413-091328>
- Naseer, S., Raja, U., Syed, F., Donia, M. B. L., & Darr, W. (2016). Perils of being close to a bad leader in a bad environment: Exploring the combined effects of despotic leadership, leader member exchange, and perceived organizational politics on behaviors. *Leadership Quarterly*, 27(1), 14–33.  
<https://doi.org/10.1016/j.leaqua.2015.09.005>
- Nazir, O., & Islam, J. U. (2017). Enhancing organizational commitment and employee performance through employee engagement: An empirical check. *South Asian Journal of Business Studies*, 6(1), 98–114.

<https://doi.org/10.1108/SAJBS-04-2016-0036>

- Ntim, C. G., Soobaroyen, T., & Broad, M. J. (2017). Governance structures, voluntary disclosures and public accountability: The case of UK higher education institutions. *Accounting, Auditing and Accountability Journal*, 30(1), 65–118. <https://doi.org/10.1108/AAJ-10-2014-1842>
- Palladan, A. P. (2018). Moderating Effects of Cyberloafing Activity on Innovative Work Behaviour and Lecturers Job Performance. *International Journal of Advanced Studies in Social Science & Innovation*, 2(1), 28–49. <https://doi.org/10.30690/ijassi.21.03>
- Ribeiro, N., Duarte, A. P., Filipe, R., & Oliveira, R. T. de. (2019). How Authentic Leadership Promotes Individual Creativity : The Mediating Role of Affective Commitment. *Journal of Leadership & Organizational Studies*, 27(2), 1–14. <https://doi.org/10.1177/1548051819842796>
- Ribeiro, N., Duarte, A. P., & Oliveira, R. T. de. (2020). How Authentic Leadership Promotes Individual Creativity: The Mediating Role of Affective Commitment. *Journal of Leadership & Organizational Studies*, 27(2). <https://doi.org/https://doi.org/10.1177/1548051819842796>
- Rubens, A., Schoenfeld, G. A., Schaffer, B. S., & Leah, J. S. (2018). Self-awareness and leadership: Developing an individual strategic professional development plan in an MBA leadership course. *International Journal of Management Education*, 16(1), 1–13. <https://doi.org/10.1016/j.ijme.2017.11.001>
- Ruck, K., Welch, M., & Menara, B. (2017). Employee voice: An antecedent to organisational engagement? *Public Relations Review*, 43(5), 904–914.
- Shaukat, R., & Khurshid, A. (2022). Woes of silence: the role of burnout as a mediator between silence and employee outcomes. *Personnel Review*, 51(5), 1570–1586. <https://doi.org/10.1108/PR-07-2020-0550>
- Sumarmi, S., Qamari, I. N., & Saad, M. S. M. (2023). Organizational Citizenship Behavior Predictors: a Mediation Analysis on Savings and Loan Cooperative. *Journal of Law and Sustainable Development*, 11(4), 1–21. <https://doi.org/10.55908/sdgs.v11i4.614>
- Sumarmi, S., Winarni, T., & Sumarni, M. (2022). Transformational Leadership and Organizational Citizenship Behavior in the COVID-19 Era: Mediating Analysis. *KnE Social Sciences*, 2022, 855–867. <https://doi.org/10.18502/kss.v7i14.12037>
- Sun, Y., & Xia, H. (2018). Research on Perceptions of Organizational Politics and Its Influence on Employee Silence. *Open Journal of Business and Management*, 06(02), 250–264. <https://doi.org/10.4236/ojbm.2018.62018>
- Tijani, O. O., & Okunbanjo, O. I. (2020). Authentic Leadership and Organizational Commitment: Empirical Evidence from Information Technology Industry in Nigeria. *Kelaniya Journal of Management*, 9(2), 55–74. <https://doi.org/10.4038/kjm.v9i2.7590>
- Ullah, S., Hasnain, S. A., Khalid, A., & Aslam, A. (2019). Effects of Perception of Organizational Politics on Employee ' s Well-Being : The Mediating Role of Trust and Interpersonal Conflicts. *European Online Journal of Natural and Social Sciences*, 8(1), 1–14. [http://european-science.com/eojnss\\_proc/article/view/5637](http://european-science.com/eojnss_proc/article/view/5637)
- Vardarlier, P., & Akiner, Ö. (2020). Relationship Between Organizational Commitment and Organizational Silence: A Study in the Insurance Industry. In *The Palgrave Encyclopedia of Strategic Management*. [https://doi.org/10.1057/978-1-349-94848-2\\_739-1](https://doi.org/10.1057/978-1-349-94848-2_739-1)
- Walumbwa, F. O., Avolio, B. J., Gardner, W. L., Wernsing, T. S., & Peterson, S. J. (2008). Authentic leadership: Development and validation of a theory-based measure. *Journal of Management*, 34(1), 89–126. <https://doi.org/10.1177/0149206307308913>
- Wiltshire, J., Bourdage, J. S., & Lee, K. (2014). Honesty-Humility and Perceptions of Organizational Politics in Predicting Workplace Outcomes. *Journal of Business and Psychology*, 29(2), 235–251. <https://doi.org/10.1007/s10869-013-9310-0>
- Yamane, T. (1967). *Elementary Sampling Theory* (1st ed.). Prentice Hall.
- Zikmund, W., Babin, B., Carr, J., & Griffin, M. (2010). Business Research Methods Eight Edition. In *South Western Educ Pub*.

4. Pemberitahuan dari Editor jika masih ada Revisi Minor

Decision: **Minor revision**

---

September 17, 2024 JEM-00364-2024-02

Authentic Leadership and Employee Silence Intention: Mediated by Perceptions of Organizational Politics and Organizational Commitment

Dear Dr. Sumarmi,

Thank you for submitting your interesting work entitled Authentic Leadership and Employee Silence Intention: Mediated by Perceptions of Organizational Politics and Organizational Commitment to the Journal of Economics and Management (JEM). We are pleased to inform you that your paper has received positive reviews indicating the need for minor revisions. To proceed with publication, it is essential that you thoroughly revise the paper following the enclosed reviews and comments from the Editor-in-Chief.

When revising your manuscript, please mark the changes using colored text, as papers without colored text will not be processed further. Additionally, note that we cannot accept your paper until you provide a camera-ready copy, which should be proofread and free of punctuation, spelling, editorial, and grammar errors.

For your convenience, you will need to submit two files:

1. The first document should contain your fully formatted revised paper, adhering to the specifications outlined in the "Requirements of Papers" section under the "For Authors" tab.
2. The second document is the Revisions Document, where you should provide a detailed, point-by-point explanation of how you have revised the submission in response to the comments from the reviewers and the Editor-in-Chief. You can find a template for this document under the "JEM's Revisions Document" file on the "For Authors" tab /<https://www.ue.katowice.pl/en/units/journal-of-economics-and-management/for-authors.html/>.

Please AVOID ENTERING ANY PERSONAL DATA into these documents. Revision deadline: 2024-10-04

For any additional questions, please get in touch with us at [jem.submission@ue.katowice.pl](mailto:jem.submission@ue.katowice.pl). Once again, thank you for submitting your manuscript to JEM, and we look forward to receiving your revision.

Sincerely,  
Monika Eisenhardt, Managing Editor

-----  
Journal of Economics and Management University of Economics in Katowice, Poland e-mail: [jem.submission@ue.katowice.pl](mailto:jem.submission@ue.katowice.pl)  
website: <https://sciendo.com/journal/JEMUEKAT>; [www.ue.katowice.pl/jem](http://www.ue.katowice.pl/jem)

**Review 1:**

The Author made significant improvements to the reviewed paper including all recommendations from the first round review. Therefore I assess the reviewed paper positively and recommend it for publication in the "Journal of Economics and Management".

**Review 2:**

Thank you very much for your additional work and upgrading the text.

**Review 3:**

Dear Editor,

The corrections made by the author/s are acceptable to me. Kindly accept for publication

**Files:**

[JEM-00364-2024-02 Comments.docx](#)



5. Tanggal 19 September 2024, author melakukan submit revisi minor.

Number of paper: JEM-00364-2024-02

Title of paper: Authentic Leadership and Employee Silence Intention: Mediated by Perceptions of Organizational Politics and Organizational Commitment

Data: Response Comment

Reviewer 1 comments	Revision
The Author made significant improvements to the reviewed paper including all recommendations from the first round review. Therefore I assess the reviewed paper positively and recommend it for publication in the "Journal of Economics and Management".	We are grateful for the positive comments and recommendations so that this article can be published in "The Journal of Economics and Management" after we have made improvements by considering the reviewers' comments. This trust motivates us to continue producing research work in the future.
Reviewer 2 comments	Revision
Thank you very much for your additional work and upgrading the text.	Thank you for your positive review; it motivates us to do research in the future.
Reviewer 3 comments (if applicable)	Revision
The corrections made by the author/s are acceptable to me. Kindly accept for publication	Thank you for the hard work of the reviewers and the positive reviews for correcting our manuscript. In addition, they also recommended that the editor publish our paper. This trust motivates us to continue producing research work.
Editor-in Chief's comments	Revision
For improved readability and understanding, please make the following corrections: 1. Add the following sentence and move the table from the Appendix to this section. 2. In this table, provide the short name used in Figure 1 and the acronyms used in Figure 2 for each item.	Thank you for your review. We have improved by adding sentences as suggested and moving the table from the appendix. In addition, we have also used short names to clarify items.
I propose to use constructs and verify this terminology in the whole article. Model includes constructs which are described by items (variables).	Thank you for suggesting using the construct. We have replaced this terminology in the article.
Fit tables to the margins.	Thanks for the suggestion. We've adjusted the table with margins.
Use item abbreviations listed in new Table 1 and presented in Figure 2.	Thanks for the suggestion. We've added item abbreviations to the table.
A decimal point is used in English. Revise all numbers.	Thank you for the corrections. We have made improvements to the decimal points in this paper.

## **Authentic Leadership and Employee Silence Intention: Mediated by Perceptions of Organizational Politics and Organizational Commitment**

### **Abstract**

**Aim/Purpose** – This study examines authentic leadership's influence on employee silence intention, mediated by perceptions of organizational politics and organizational commitment.

**Design/methodology/approach** – Research data was obtained through a survey of 251 lecturers at PGRI universities. The method used to analyze the data was structural equation modeling with AMOS.

**Findings** – The research results show that authentic leadership, perceptions of organizational politics, and organizational commitment have a direct effect on employee silence intention. In addition, Perceptions of organizational politics and organizational commitment mediate the influence of authentic leadership on employee silence intention.

**Research implications/limitations** – The theoretical implications of this study strengthen the theory of authentic leadership by demonstrating its negative influence on employee silence intentions. However, a limitation of this study lies in the potential need for more generalizability of the findings, as the study focused only on higher education, so the results may not fully apply to different industries or cultural contexts.

**Originality/value/contribution** – This research makes a significant contribution by exploring the influence of authentic leadership on employee silence intention. It enriches the literature with empirical findings linking leadership honesty, openness, and transparency to reduced employee silence.

**Keywords:** authentic leadership, perceptions of organizational politics, organizational commitment, employee silence intention

**JEL Classification:** M12, M54, O15

### **4. Introduction**

Employees' silence when discussing work-related matters has many consequences for individuals, teams, and organizations (Hao et al., 2022). This is because employees are capital with a central role in organizational activities to mobilize and synergize other resources to achieve predetermined goals. (Eckardt et al., 2021; Febriansyah et al., 2019). In the process of achieving performance, it is not uncommon for problems to arise from interactions between employees and colleagues, as well as employees and leaders. However, employees are reluctant to voice problems that arise in the workplace and tend to ignore these problems (Morrison, 2014). This condition is triggered by a dilemma between considering the short-term interests of the leader, who may view voicing a problem as an act of disloyalty, and the organization's long-term interests, which may experience severe costs due to silence (Monzani et al., 2016).

Employee silence is not only related to problems between employees but also to expressing opinions, even though employees have a lot of knowledge and experience that can be used to improve organizational performance (Shaukat & Khurshid, 2022). Employee silence intention is a failure to convey important information to the authorities, which can cause problems for the organization (John & Manikandan, 2019). Previous studies on employee silence intention used this variable as a predictor, such as the impact on organizational turnover intention Al Muala et al. (2022), well-being, job attitude, and performance (Hao et al., 2022). Researchers intend to investigate employee silence intention as an outcome and use authentic leadership as a predictor.

*Authentic leadership* is defined Walumbwa et al. (2008) as a pattern of leadership behavior that explains and expands positive psychological abilities and a positive moral atmosphere to develop self-awareness, internal moral outlook, balanced information processing, and transparency of communication with followers. An authentic leader will positively affect organizational performance, and the positive impact of an authentic leader on team performance is more robust among employees with high social capital (Akhtar et al., 2021). The self-regulatory behavior inherent in the authentic leadership process shapes collective team behavior, which emerges in the process of team reflexivity, which in turn predicts team performance positively (Lyubovnikova et al., 2015). It is hoped that the leadership pattern of an authentic leader will reduce employee silence intention among employees. This is because authentic leaders can create a safe and trusting environment where team members can work effectively (Maximo et al., 2019). Studies conducted Abdillah et al. (2022; Guenter et al. (2017) found a negative relationship between authentic leadership and silent behavior. Meanwhile Monzani et al., (2016) use a form of silence behavior at the organizational level, namely Exit, Voice, Neglect, and Loyalty, and found a negative relationship between authentic leadership and exit and neglect. Meanwhile, authentic leadership, Loyalty, and Voice have a positive relationship.

In the social environment today, social politics is developing a lot in society and organizations, which is referred to as organizational politics (Sun & Xia, 2018). Differences in political perceptions in the organization that occur between employees, if not managed well, will have a negative impact on the organizational climate (Naseer et al., 2016). Perceptions of organizational politics refers to the maximization of personal interests by organizational members using methods that are not recognized by the formal rules of the organization to influence the distribution of benefits within the organization (Eldor, 2017; Kacmar & Baron, 1999). Research results show that the negative impact of perceptions of organizational politics in the workplace is exacerbated for employees with lower levels of honesty and humility (Wiltshire et al., 2014). Buchanan (2008), states that negative Perceptions of organizational politics can cause employees to feel insecure or worry about the consequences of expressing dissatisfaction. Employees who feel insecure or worried may be more likely to remain silent rather than risk coming forward (Behtoui et al., 2017). Authentic leadership brings transparency into decision-making so leaders can reduce misunderstandings (Alvesson &

Einola, 2019). Additionally, transparency reduces the space for negative perceptions such as favoritism or hidden agendas, often related to office politics (Haavisto & Linge, 2022). As role models, authentic leaders demonstrate anti-political behavior (Fawcett & Corbett, 2018).

Organizational commitment is a crucial link between authentic leadership and employees' silence intention. Organizational commitment, a measure of the degree of employee involvement and participation in the organization Sumarmi et al. (2023), can be fostered by authentic leadership, leading to a decrease in employee silence intention. Authentic leaders, as highlighted by Maximo et al. (2019), tend to exhibit consistent, predictive, and reliable behavior, which helps in building trust and psychological safety among employees. Employees who perceive high levels of honesty and transparency from their leaders are more likely to develop greater respect and dedication to the organization (Jiang & Luo, 2018). This commitment strengthens employee identification with the values and goals of the organization, thereby increasing organizational commitment (Nazir & Islam, 2017).

## **5. Literature review**

### **5.1. Authentic leadership and employee silence intention**

This exploration will address the relationship between authentic leadership and two critical aspects of employee behavior and perceptions: employee silence intention and perceptions of organizational politics. Leaders who embody authentic leadership, emphasizing honesty, integrity, transparency, and authenticity in their interactions with subordinates Jiang & Luo (2018), create an environment where employees feel more comfortable and are encouraged to discuss the problems or concerns they face openly. This approach is expected to reduce the tendency to remain silent significantly (Kelly, 2023). Employee silence intention often stems from the perceptions that speaking openly is unsafe due to the fear of negative consequences or retaliation from management or co-workers (MacMahon et al., 2018). However, through strong, mutually beneficial relationships with subordinates, an authentic leader can foster an inclusive and supportive work environment. Therefore, robust, authentic leadership is anticipated to reduce employee silence in the organization, leading to a more positive and open workplace.

Based on this explanation, the first hypothesis is formulated as follows:

**H1:** Authentic leadership is negatively related to employee silence intention.

### **5.2. Authentic leadership and perceptions of organizational politics**

Authentic leadership, characterized by honesty, consistency, and self-awareness, has a profound impact on employees' perceptions (Jiang & Luo, 2018). This leadership style, rooted in self-awareness and a deep understanding of values, strengths, and weaknesses, fosters a positive work environment (Rubens et al., 2018). Employees under the guidance of authentic leaders often develop more

positive perceptions of fairness and transparency within the organization Liu (2017), instilling a sense of hope and optimism in the workplace.

On the other hand, perceptions of organizational politics refer to employees' subjective views regarding the existence of political practices, nepotism, or manipulation of power within the organization (Jeong & Kim, 2022). This condition can cause employee job dissatisfaction because they feel unfair or unappreciated for their achievements or contributions. Organizational political practices can also damage trust between employees, management, and co-workers (Ullah et al., 2019). Authentic leadership emphasizing transparency, honesty, and self-awareness will reduce unethical political practices in organizations. Authentic leaders build a culture where decisions and promotions are based on performance and values, not internal politics or personal relationships.

Based on this explanation, the second hypothesis is formulated as follows:

**H2:** Authentic leadership is negatively related to perceptions of organizational politics.

### **5.3. Authentic leadership and organizational commitment**

Avolio & Gardner (2005), Highlight the significant impact of authentic leadership in building trust and commitment among followers, where leaders who demonstrate honesty, integrity, and self-awareness can create an environment where employees feel valued and supported, leading to higher levels of commitment to the organization. Employees in an organization will develop a strong emotional attachment (affective commitment), perceive few costs associated with leaving the organization (continuance commitment), and feel a moral obligation to stay with the organization (normative commitment) (Ahmad, 2018; Palladan, 2018). Therefore, higher levels of authentic leadership are expected to result in higher levels of organizational commitment among employees.

The study Walumbwa et al. (2008) discovered a robust positive correlation between authentic leadership and followers' commitment to the organization. Further studies Hadian Nasab & Afshari, (2019); Ullah et al., (2019) have also confirmed this positive relationship. Drawing from these empirical findings, the third hypothesis is formulated as follows:

**H3:** Authentic leadership is positively related to organizational commitment.

### **5.4. Perceptions of organizational politics and employee silence intentions**

Perceptions of organizational politics refers to employees' subjective perceptions of political behavior, favoritism, or manipulation of power within the organization (Khuwaja et al., 2020). Lam & Xu (2019), highlights the detrimental effects of perceived organizational politics on employee attitudes and behavior, where employees who perceive higher levels of organizational politics are more likely to experience job dissatisfaction, reduced organizational commitment, and higher stress and turnover intentions. Higher. In addition, Ferris et al., (2007) conducted a meta-analysis that examined the relationship between perceptions of organizational politics and employee silence behavior and revealed a significant positive relationship between perceptions of organizational politics and employee silence intentions. Employees who perceive high levels of organizational

politics may remain silent to avoid potential retaliation or ostracism from superiors or coworkers (Jahanzeb et al., 2018).

Perceptions of organizational politics create a work environment characterized by distrust, fear, and uncertainty among employees and trigger employees to remain silent and refrain from expressing their ideas, opinions, or concerns, even when doing so could benefit the organization. Studies Khalid & Ahmed (2016); Sun & Xia (2018), found a positive relationship between perceptions of organizational politics and employee silence. Based on this explanation, hypothesis 4 in this research is as follows.

**H4:** Perceptions of organizational politics are positively related to employee silence intention

### **5.5. Organizational commitment and employee silence intention**

Organizational commitment is employees' trust, involvement, and loyalty toward the organization (Sumarmi et al., 2022). This statement indicates that the higher a person's level of organizational commitment, the lower the possibility of showing behavior contrary to the organization's interests, such as remaining silent about potentially detrimental issues (Allen et al., 2017). The silence carried out by employees, including silence in conveying development opinions for the organization, tends to have a negative impact on the organization (Morrison, 2014). Employees who feel attached to the organization and have a high commitment to the organization tend not to remain silent about issues related to the welfare of the organization (Kim et al., 2023). The study Vardarlier & Akiner (2020) also found a negative relationship between organizational commitment and employee silence intention.

Based on the explanation above, the fifth hypothesis is as follows:

**H5:** Organizational commitment is negatively related to employee silence intention

### **5.6. The mediating effect of perceptions of organizational politics and organizational commitment**

Employees led by authentic leaders tend to have a more positive perceptions of organizational culture Koontz (2021), because it can create a supportive work environment where employees feel heard, appreciated, and encouraged to participate actively. In addition, an organizational culture influenced by authentic leadership will reduce employees' tendency to have political perceptions, thereby reducing employees' reticence to express opinions (Bakari et al., 2018). In an environment like this, employees feel safer to express opinions without fear of negative consequences.

Based on this explanation, the sixth hypothesis is as follows:

**H6:** Perceptions of organizational politics mediate the negative relationship between authentic leadership and employee silence intention.

Apart from the explanation above, the impact of authentic leaders is that employees become more identified with the values and goals of the organization so that they can increase their commitment to the organization (Ribeiro et al., 2019). This arises because leaders represent the values that employees believe in and support. Strong organizational commitment from employees will

encourage employees to share information and relevant issues actively rather than remaining silent (Morrison, 2014). Based on this explanation, the seventh hypothesis is formulated as follows:

**H7:** Organizational commitment mediates the negative relationship between authentic leadership and employee silence intention.

The relationship between constructs in the seven hypotheses above is presented in Figure 1. For each construct, indicators are also listed to measure the construct.

**Figure 1. Research Model**

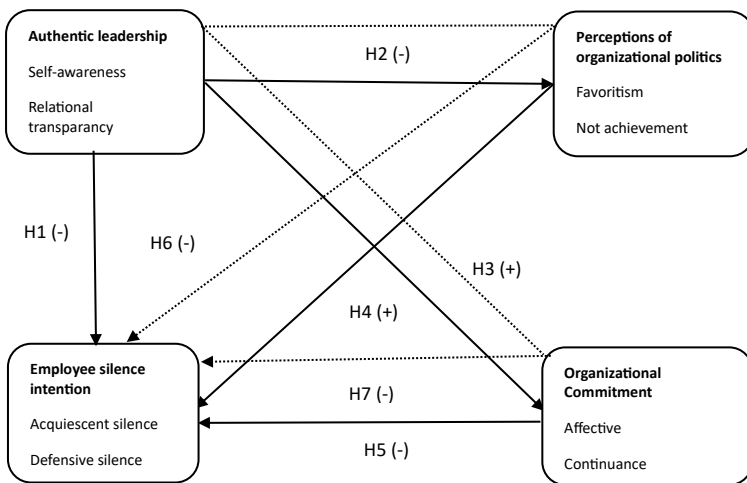

Source: Author's elaboration (2024)

## 6. Research methodology

### 6.1. Sample and Data Collection

Our sampling method was distinct, utilizing a non-probability approach. This means that elements in the population were not uniformly likely to be selected as sample subjects. We employed a purposive sampling technique, a non-probability method where samples are selected based on specific characteristics deemed relevant by the researchers. This approach allows for the targeted selection of individuals who meet particular criteria essential for the study (Zikmund et al., 2010). In this study, we focused on 29 PGRI universities on the island of Java, Indonesia and 251

lecturers as respondents. PGRI is an abbreviation of "Persatuan Guru Republik Indonesia," or the Republic of Indonesia Teachers Association in English. The research was conducted at a university because academics have well-documented policies, and the unique pressures and politics at universities provide insight into how authentic leadership can reduce negative impacts on employee behavior, thereby increasing the generalizability of the findings to other contexts.

The population of this study was 1055 permanent lecturers of the PGRI foundation. Using the Slovin formula Yamane (1967)(Yamane, 1967), and calculations using the Slovin calculator and the formula above, the number of samples was 290,034.

$$n = \frac{N}{1+N(e)^2} \quad (1)$$

Description:

n = sample size/number of respondents

N = population size

e = percentage of tolerance for sampling error accuracy (Yamane, 1967).

$$n = \frac{1055}{1+1055(0,05)^2} \quad (2)$$

$$n = 290,034 \quad (3)$$

Since this study used 29 universities, the researchers took 10 respondents from each. Because this study used 29 universities, the researcher took 10 respondents from each. After waiting two months, respondents planned to fill out the questionnaire, but only 251 data could be analyzed.

Data collection was carried out using a questionnaire distributed through Google Forms. Before the respondents filled out the questionnaire, the researcher sent a message via personal network to the Vice Chancellor for Human Resource Development to assign lecturers to fill out the questionnaire. This research was conducted from March to May 2024. After waiting two months, the respondents planned to complete the questionnaire, but only 251 data could be analyzed. The educational level of lecturers is 64,9 % have a Master's degree, and 35,1 have a Doctoral degree. Tenure of lecturers at universities < 5 years by 25,5 %; > 5 – 10 years by 35,5 %; > 10 – 15 years by 24,7 %; > 15 – 20 years by 11,9 %; and > 20 years by 2,4 %. Most lecturers' academic positions are Asistant Professor at 47,41 %, Associate Professor at 13,94 %, and Lecturer at 38,65 %.

## 6.2. Measurements

Authentic leadership, a key focus of our study, was measured using developed dimensions (Kelly, 2023; Ribeiro et al., 2020; Walumbwa et al., 2008). These dimensions include Self-awareness, Relational transparency, Balanced processing, and Internalized moral perspective. To provide a clear picture, we included examples of questionnaire items that reflect these dimensions, such as "Leaders always seek feedback to improve interactions with others" and "Leaders listen carefully and consider different points of view before concluding."

Leadership in higher education differs significantly from leadership in companies and corporations due to several unique factors. First, higher education has a more decentralized organizational structure with greater autonomy for each faculty and department (Frølich et al., 2019). This requires a leadership style that accommodates a diversity of opinions and a more collaborative approach. Authentic leadership is particularly relevant in this context because it



emphasizes transparency, honesty, and integrity, which can build a safe and trusting environment for faculty to share their ideas and opinions without fear of reprisal (Maximo et al., 2019; Ribeiro et al., 2020). In addition, higher education has a dual mission of teaching, community service, and research that requires a flexible and supportive leadership approach (McCaffery, 2018). Authentic leadership can help create an academic culture that supports innovation and creativity by providing genuine support and recognition to faculty for their contributions (Alzghoul et al., 2018). In academic environments, where collaboration and professional development are highly valued, authentic leadership can increase faculty commitment to the institution and strengthen their involvement in decision-making processes (Elrehail et al., 2017). Finally, political pressures and dynamics in higher education often differ from those in companies and corporations (Ntim et al., 2017). Authentic leadership that encourages open and honest communication can reduce negative perceptions of organizational politics and increase clarity and fairness in decision-making. Thus, authentic leadership in higher education promotes the psychological health and well-being of faculty and enhances the organization's effectiveness and performance as a whole.

Perception of organizational politics was measured using items developed Ferris & Kacmar (1992); Jeong & Kim (2022); Ullah et al. (2019), namely: Favoritism, not achievement, determines who is superior; you can get along here by being a good person, regardless of the quality of your work; and there are "clusters" or "clusters" that hinder effectiveness here.

Employee silence intention is measured using the dimensions of acquiescent silence, defensive silence, prosocial silence, and opportunistic (Hao et al., 2022; Harlos & Knoll, 2021). One item indicates the extent to which employees remain silent, such as "I prefer to remain silent rather than voice my opinion when faced with phenomena that affect work efficiency."

Organizational Commitment is measured using the dimensions of Nasab & Afshari (2019); Meyer et al., (1993), is affective, continuance, and normative. An example item is, "I feel proud to tell other parties that I am part of the PGRI organization."

In summary, the measurement items are specified in Table 1.

**Table 1.** Constructs and Items

Construct	Item	Item Abbreviation
Authentic Leadership	Leaders at our college accurately describe how others view their abilities.	SF- Self awareness
	Leaders always seek feedback to improve interactions with others	RT- Relational transparency
	Leaders at our colleges demonstrate beliefs consistent with action.	BP- Balanced Processing
	Leaders listen carefully and consider different points of view before concluding	IMP- Internalized Moral Perspective

Perceptions of Organizational Politics	The deciding factor for winning here is not merit, but rather favoritism.	F- Favoritism
	Leaders in these organizations frequently employ selection procedures to exclusively recruit individuals who can offer assistance in the future or share similar perspectives.	NP- not achievement
	Success depends on knowing the right people and seeking their help when needed.	A There are clusters
	There are always influential groups in these organizations due to gender, regionalism, school ties, and kinship.	G- Being a good person
Organizational Commitment	I stay with this organization because I value loyalty and feel a moral obligation to remain.	AC- Affective commitment
	I feel proud to tell other parties that I am part of the PGRI organization	CC- continuance commitment
	I am eager to commit to a long and successful career with this organization.	NC- Normative commitment
Employee Silence Retention	I believe it might be unsafe to voice my concerns.	AS- Aquiescent silence
	I was concerned that sharing my thoughts and concerns could have a detrimental effect on my professional advancement.	DS- Defensive silence
	To deliberately inflict harm on another individual.	PS- Prosocial silence
	I think expressing my thoughts and worries could potentially hinder my career progression.	OS- Opportunistic Silence

The measurement scale for the four constructs uses a Likert scale of 1 to 5. The measurement scale of the four constructs uses a Likert scale of 1 to 5. For authentic leadership and organizational commitment, Scale 1 means Strongly disagree, Scale 2 disagree, Scale 3 neutral, Scale 4 agree, and Scale 5 means strongly agree. Perception of organizational politics and employee silence intention means the opposite, where scale 1 means Strongly agree, scale 2 agree, scale 3 neutral, Scale 4 disagree, and Scale 5 means strongly disagree.

### 6.3. Data analysis technique

Research data analysis began by testing the validity of the factorial structure, which was carried out through the use of confirmatory factor analysis (CFA) within a structural equation modeling (SEM) framework (Byrne, 2001). The hypothesis was tested using structural equation modeling, and the researcher used CB-SEM AMOS.

## 7. Research findings

The initial research stage was conducted by testing the instrument through reliability and construct validity. Based on the results of data analysis, the estimated Standardized Regression Weight value for all statement items is above 0,5, as presented in Table 2. This obtained value can be interpreted if all questionnaire items are declared valid. The reliability test can be determined from the CR and AVE values presented in Table 2. From the calculation results, the CR value is above 0,9, and the AVE value is above 0,5, so all questionnaire items are also declared reliable.

Table 2. Construct reliability and validity

Constructs	Items	Loading factors	Cronbach alpha	CR	AVE
Authentic_Leadership	SF	0,721	0,910	0,91	0,71
	RT	0,915			
	BP	0,911			
	IMP	0,853			
Perceptions of Organizational Politics	F	0,705	0,919	0,91	0,71
	NP	0,907			
	A	0,921			
	G	0,816			
Organizational Commitment	AC	0,814	0,902	0,92	0,8
	CC	0,948			
	NC	0,916			
Employee Silence Retention	AS	0,952	0,899	0,89	0,69
	DS	0,942			
	PS	0,711			
	OS	0,677			

Source: processed primary data (2024)

The HTMT criterion for discriminant validity of first-order constructs, as suggested by (Hair et al., 2017), should not surpass 0,9. In the pairwise comparisons presented in Table 3, the HTMT value did not go beyond 0,9, thus confirming discriminant validity.

Table 2. Discriminant validity Heterotrait – monotrait rasion (HTMT) results

Constructs	Authentic leadership	Organizational commitment	employee silence intention
Authentic leadership			
Organizational commitment	0,792		
Employee silence intention	0,841	0,893	
Perceptions of organizational politics	0,826	0,810	0,851

Source: processed primary data (2024)

After all statement items are declared valid and reliable, a full research model analysis is carried out to test the hypothesis. The results of the hypothesis testing are presented in Figure 2, Table 3, and Table 4.

**Figure 2: Full Model Analysis**

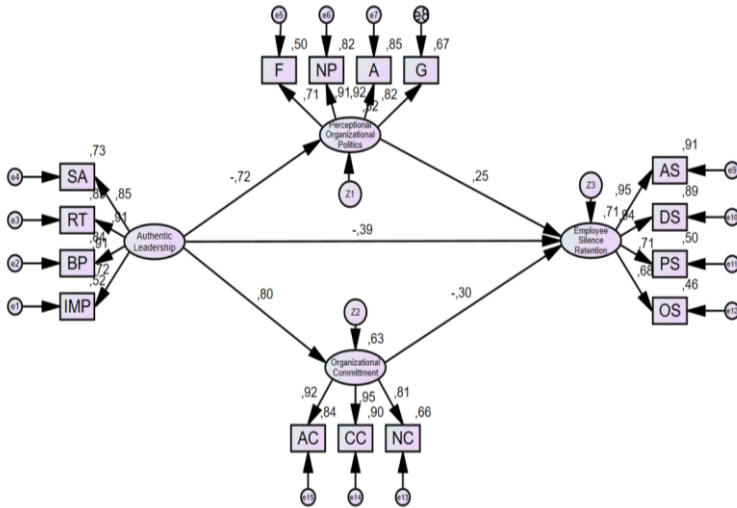

Note: SA: Self-awareness, RT: Relational transparency, BP: Balanced processing, IMP: Internalized moral perspective, F: Favoritism, NP: Not achievement, G: Being a good person, A: There a clusters, AC: Affective commitment, CC: Continuance commitment, NC: Normative commitment, AS: Acquiescent silence, DS: Defensive silence, PS: Prosocial silence, and OS: Opportunistic silence.

Based on the data analysis results in Table 3, the p-value obtained from the direct relationship between the constructs tested in hypotheses 1 – 5 is 0,000, with a statistical t-value greater than 1,96. These results show that the direct influence on hypotheses 1 – 5 is proven to be significant, so this hypothesis is supported by the research results.

**Table 3. Direct Effect Hypothesis Test Results**

Direct effect	Estimate	S.E.	CR	P	Decision
H1: Authentic_Leadership and Perceptions_Organizational_Politics	-,833	,085	9,755	0,000	Supported
H2: Authentic_Leadership and Organizational_Committment	,840	,080	10,469	0,000	Supported
H3: Perceptions_Organizational_Politics and Employee_Silence_Retention	,229	,079	2,902	0,004	Supported
H4: Organizational_Committment and Employee_Silence_Retention	-,295	,131	2,248	0,025	Supported
H5: Authentic_Leadership and Employee_Silence_Retention	-,407	,134	3,028	0,003	Supported

Source: processed primary data (2024)

Table 4 shows the output of the indirect effect analysis, where perceptions of organizational politics and organizational commitment mediate the influence of authentic leadership and employee silence intention. The p-value of the indirect relationship between authentic leadership and employee silence intention is 0,000, with a t-statistic value greater than 1,96. Likewise, the p-value of authentic leadership and employee silence intention is mediated by organizational commitment. These results indicate that the indirect effect on hypotheses 6 and 7 is significant, so the study's results support this hypothesis.

**Table 4. Indirect Effect Hypothesis Test Results**

Indirect effect	Estimate	S.E.	CR	P	Decision
-----------------	----------	------	----	---	----------

H6: Perceptions of organizational politics mediate authentic leadership and employee silence intention.	-,190	,068	2,815	0,005	Supported
H7: Organizational commitment mediates authentic leadership and employee silence intention.	-0,247	,116	2,133	0,033	Supported

Source: processed primary data (2024)

## 9. Discussion

The finding of the first hypothesis, where authentic leadership negatively influences employee silence intention, adds to the empirical findings of studies conducted (Abdillah et al., 2022; Guenter et al., 2017; Monzani et al., 2016). Based on the study findings, authentic leadership is necessary for creating a positive and productive work environment through openness, trust, and involvement, reducing employees' tendency to remain silent and encouraging more significant contributions from all team members. When employees perceive their leaders as honest and transparent, trust in them increases, reducing their apprehension about potential negative consequences when expressing their opinions (Agote et al., 2016). Employees are likelier to speak up and participate actively in discussions and decision-making. These conditions not only improve the organization's overall health but also encourage innovation and continuous improvement.

The second hypothesis is also supported by research results, where Authentic Leadership also negatively influences Perception of Organizational Politics. Authentic leaders consistently behave honestly and openly, which helps reduce suspicion and perceptions of manipulation among employees (Alvesson & Einola, 2019). When employees see that their leaders operate with integrity, their trust in the organization increases, and perceptions of organizational politics decrease (Lampaki & Papadakis, 2018). Authentic leaders also ensure that decisions are made based on fair and transparent principles, not favoritism or hidden agendas, which helps reduce the perception that political actions dominate the organization. Employees are encouraged to convey their ideas, input, and concerns without fear of reprisal or manipulation. They will create a culture where every voice is valued and considered, reducing perceptions of organizational politics (Alavi & Gill, 2016). Employee engagement increases when they feel valued and heard. Authentic leadership will help create an environment where employees feel motivated to contribute positively without getting involved in organizational politics to get ahead.

This study also proves the third hypothesis that authentic leadership positively affects organizational commitment. This study is in line with the findings of Tijani & Okunbanjo (2020), which also found a positive influence between these two variables. Honesty and transparency, emphasized in authentic leadership, will build trust between leaders and employees. When employees believe that their leaders are honest and consistent, it will create a greater sense of psychological security (Maximo et al., 2019), and this sense of security increases employees' emotional attachment (affective commitment) to the organization (Camgoz & Karapinar, 2016). Authentic leaders encourage employees to participate actively in the decision-making process and share ideas and input so that employees feel valued. A sense of appreciation makes employees more emotionally and normatively committed to the organization (Morrison, 2014).

The fourth hypothesis is also substantiated by the research, revealing that Perceptions of Organizational Politics has a detrimental effect on employee silence intention. The high perception of organizational politics among employees often instills fear of negative consequences if they voice their opinions (Morrison, 2014). Employees are concerned that expressing their views could jeopardize their position, influence performance evaluations, or make them vulnerable to retaliation by powerful individuals within the organization (Bashshur & Oc, 2015; Brinsfield, 2012). This situation breeds apathy and a reluctance to be actively involved, leading employees to choose silence. They withdraw and opt not to voice their opinions, believing that it will not positively impact their future careers.

The fifth hypothesis produces the finding that organizational commitment negatively influences employee silence intention. Employees with high commitment to the organization are emotionally attached to the organization. This attachment creates a sense of ownership and responsibility to contribute positively. It is happy to voice opinions based on concern for the success and welfare of the organization (Kim & Beehr, 2018). Employees feel that employee voices are essential for organizational development and will be heard, so they tend to reduce their intention to remain silent (Ruck et al., 2017). Moreover, with high commitment, employees have a greater sense of trust in the organization and its leaders. Employees feel safe to express their opinions without fear of negative consequences.

The study's results also support the test of the indirect effect of authentic leadership on employee silence intention mediated by dynamic adaptive capability and authentic leadership on employee silence intention mediated by organizational commitment. Perception of organizational politics is proven to mediate the negative influence of authentic leadership on employee silence intention. The findings highlight the complexity of organizational dynamics. Honest and open leaders tend to create a work environment where employees feel safe and can voice opinions without fear of negative repercussions (Jha & Singh, 2019). This honesty and openness directly reduce employee intentions to remain silent. However, authentic leadership is essential, and reducing perceptions of politics within the organization is crucial in encouraging open communication and reducing employee intentions to remain silent (Kim et al., 2023). Even in organizations with authentic leadership, employees may remain hesitant to voice their opinions if they perceive a high level of organizational politics. It is based on the idea that open communication will not be protected or valued in an environment dominated by organizational politics. Therefore, organizations must work proactively to create a transparent, fair, and supportive work environment to achieve these goals (Chang et al., 2022).

The finding that organizational commitment mediates the negative influence of authentic leadership on employees' intention to remain silent underscores the importance of fostering strong and committed relationships between employees and the organization. This finding reiterates the main message of the research, which is that authentic leadership not only promotes openness and trust in the workplace but also strengthens employee commitment, thereby reducing their tendency to remain silent. The research suggests that organizations should focus on developing authentic leadership and commitment-enhancing strategies to create a more open and productive work environment. This, in turn, encourages employees to speak up and share their ideas for the benefit of the organization, thereby reinforcing the importance of the research findings.

## 10. Conclusions

This study confirms that authentic leadership hurts employees' intention to remain silent, and perceptions of organizational politics and organizational commitment mediate this effect. Authentic leadership characterized by honesty, openness, and transparency can create a more positive, productive, and politically free work environment, reducing employees' tendency to remain silent. In addition, employees who feel valued and trust their leaders tend to be more committed to the university and are more courageous in voicing their opinions.

The theoretical implications of this research strengthen authentic leadership theory by adding empirical evidence about its negative influence on employee intentions to remain silent. This implication shows that authentic leadership influences employee performance and well-being and plays an essential role in reducing employee silence. It also adds to the literature on organizational politics by showing that authentic leadership can reduce perceptions of organizational politics, reducing employee intentions to remain silent. This study expands the understanding of how organizational commitment mediates the relationship between authentic leadership and employees' silence intention to remain silent, suggesting that increasing employee commitment can play an essential role in creating a more open and collaborative work environment.

The practical implications of this study are clear. Universities should prioritize leadership development through training programs emphasizing honesty, transparency, and openness. Additionally, management should actively seek to reduce organizational politics by implementing fair and transparent policies and avoiding favoritism. These steps are crucial to creating a healthier and more open work environment.

It is essential to note the limitations of this study. The findings, while significant, may only be universally applicable to some industries or cultures. Therefore, further research is needed to validate the findings in different contexts, ensuring the robustness and reliability of the study's conclusions.

Suggestions for future research include contextual studies. Conducting research across industries and cultures can strengthen the generalizability of these findings and help understand how context influences these relationships. Further research could explore additional mediator or moderator variables that may influence these relationships, such as organizational culture, psychological climate, and communication style.

#### **11. Declaration of competing interest**

The author declares that there is no potential conflict of interest.

#### **12. Funding**

The research was supported by xxxxxxxxx (should be added after review)

#### **References (Times New Roman, 12-point, bold, left aligned, line spacing: single)**

- Abdillah, M. R., Anita, R., Agusanto, A., & Rahmat, A. (2022). Authentic Leader and Employee's Silence Behavior: Testing a Happiness at Work Mechanism. *INOBI: Jurnal Inovasi Bisnis Dan Manajemen Indonesia*, 5(4), 443–460. <https://doi.org/10.31842/jurnalnobis.v5i4.243>
- Agote, L., Aramburu, N., & Lines, R. (2016). Authentic Leadership Perception, Trust in the Leader, and Followers' Emotions in Organizational Change Processes. *Journal of Applied Behavioral Science*, 52(1), 35–63.

<https://doi.org/10.1177/0021886315617531>

- Ahmad, A. (2018). The relationship among job characteristics organizational commitment and employee turnover intentions: A reciprocation perspective. *Journal of Work-Applied Management*, 10(1), 74–92. <https://doi.org/10.1108/JWAM-09-2017-0027>
- Akhtar, M. W., Aslam, M. K., Huo, C., Akbar, M., Afzal, M. U., & Rafiq, M. H. (2021). The interplay of authentic leadership and social capital on team leader performance in public and private sector universities. *Kybernetes*, 1. <https://doi.org/10.1108/K-06-2021-0446>
- Al Mualla, I., Al-Ghalabi, R. R., Alsheikh, G. A. A., Hamdan, K. B., & Alnawafleh, E. A. T. (2022). Evaluating the Effect of Organizational Justice on Turnover Intention in the Public Hospitals of Jordan: Mediated-Moderated Model of Employee Silence, Workplace Bullying, and Work Stress. *International Journal of Professional Business Review*, 7(3), 1–23. <https://doi.org/10.26668/businessreview/2022.v7i3.0526>
- Alavi, S. B., & Gill, C. (2016). Leading Change Authentically : How Authentic Leaders Influence Follower Responses to Complex Change. *Journal of Leadership & Organizational Studies*, 24(2), 1–15. <https://doi.org/10.1177/1548051816664681>
- Allen, D. G., Pelkotorpi, V., & Rubenstein, A. L. (2017). When “embedded” means “stuck” : moderating effects of job embeddedness in adverse work environments. *Journal of Applied Psychology*, 101(2016), 1670–1686.
- Alvesson, M., & Einola, K. (2019). Warning for excessive positivity: Authentic leadership and other traps in leadership studies. *Leadership Quarterly*, 30(4), 383–395. <https://doi.org/10.1016/j.leaqua.2019.04.001>
- Alzghoul, A., Elrehail, H., Emeagwali, O. L., & AlShboul, M. K. (2018). Knowledge management, workplace climate, creativity and performance: The role of authentic leadership. *Journal of Workplace Learning*, 30(8), 592–612. <https://doi.org/10.1108/JWL-12-2017-0111>
- Avolio, B. J., & Gardner, W. L. (2005). Authentic leadership development: Getting to the root of positive forms of leadership. *Leadership Quarterly*, 16(3), 315–338. <https://doi.org/10.1016/j.leaqua.2005.03.001>
- Bakari, H., Hunjra, A. I., Shabbir, G., & Niazi, K. (2018). How Does Authentic Leadership Influence Planned Organizational Change ? The Role of Employees ' Perceptions : Integration of Theory of Planned Behavior and Lewin ' s Three Step Model. *Journal of Change Management*, 17(2), 1–33. <https://doi.org/10.1080/14697017.2017.1299370>
- Bashshur, M. R., & Oc, B. (2015). When Voice Matters: A Multilevel Review of the Impact of Voice in Organizations. *Journal of Management*, 41(5), 1530–1554. <https://doi.org/10.1177/0149206314558302>
- Behtoui, A., Boréus, K., Neergaard, A., & Yazdanpanah, S. (2017). Speaking up, leaving or keeping silent: Racialized employees in the Swedish elderly care sector. *Work, Employment and Society*, 31(6), 954–971. <https://doi.org/10.1177/0950017016667042>
- Brinsfield, C. T. (2012). Employee silence Motives: Investigation of diemnsionality and development of measures. *Journal of Organizational Behavior*, 60(1), 5–22. <https://doi.org/10.1002/job.1829>
- Buchanan, D. A. (2008). You stab my back, I'll stab yours: Management experience and perceptions of organization political behaviour. *British Journal of Management*, 19(1), 49–64. <https://doi.org/10.1111/j.1467-8551.2007.00533.x>
- Byrne, B. M. (2001). Structural Equation Modeling With AMOS , EQS , and LISREL : Comparative Approaches to Testing for the Factorial Validity of a Measuring Instrument. *International Journal of Testing*, 1(1), 55–86.
- Camgoz, S. M., & Karapinar, P. B. (2016). Linking secure attachment to commitment: trust in supervisors. *Leadership & Organization Development Journal*, 34(1), 1–5.
- Chang, P. C., Ma, G., & Lin, Y. Y. (2022). Inclusive Leadership and Employee Proactive Behavior: A Cross-Level Moderated Mediation Model. *Psychology Research and Behavior Management*, 15, 1797–1808. <https://doi.org/10.2147/PRBM.S363434>
- Eckardt, R., Tsai, C. Y., Dionne, S. D., Dunne, D., Spain, S. M., Park, J. W., Cheong, M., Kim, J., Guo, J., Hao, C., & Kim, E. Il. (2021). Human capital resource emergence and leadership. *Journal of Organizational Behavior*, 42(2), 269–295. <https://doi.org/10.1002/job.2446>
- Eldor, L. (2017). Looking on the Bright Side: The Positive Role of Organisational Politics in the Relationship between Employee Engagement and Performance at Work. *Applied Psychology*, 66(2), 233–259.



<https://doi.org/10.1111/apps.12090>

- Elrehail, H., Emeagwali, O. L., Alsaad, A., & Alzghoul, A. (2017). The Impact of Transformational and Authentic Leadership on Innovation in Higher Education : The Contingent Role of Knowledge Sharing. *Telematics and Informatics*. <https://doi.org/10.1016/j.tele.2017.09.018>
- Fawcett, P., & Corbett, J. (2018). Politicians, professionalization and anti-politics: why we want leaders who act like professionals but are paid like amateurs. *Policy Sciences*, *51*(4), 411–432. <https://doi.org/10.1007/s11077-018-9323-7>
- Febriansyah, Sumarmi, S., & Haryono, S. (2019). Pengaruh Kepemimpinan, Kemampuan Kerja Terhadap Kinerja Pegawai Dinas Pendidikan Provinsi Sumsel Dimediasi Motivasi Kerja. *Jurnal Ekonomi Manajemen Sumber Daya*, *22*(1), 21–28. <https://journals.ums.ac.id/index.php/dayasaing/article/view/10704>
- Ferris, G. R., & Kacmar, K. M. (1992). Perceptions of Organizational Politics. *Journal of Management*, *18*(1), 93–116.
- Ferris, G. R., Treadway, D. C., Perrewé, P. L., Brouer, R. L., Douglas, C., & Lux, S. (2007). Political skill in organizations. *Journal of Management*, *33*(3), 290–320. <https://doi.org/10.1177/0149206307300813>
- Frølich, N., Christensen, T., & Stensaker, B. (2019). Strengthening the strategic capacity of public universities: The role of internal governance models. *Public Policy and Administration*, *34*(4), 475–493. <https://doi.org/10.1177/0952076718762041>
- Guenter, H., Schreurs, B., van Emmerik, I. H., & Sun, S. (2017). What Does it Take to Break the Silence in Teams: Authentic Leadership and/or Proactive Followership? *Applied Psychology*, *66*(1), 49–77. <https://doi.org/10.1111/apps.12076>
- Haavisto, V. E., & Linge, T. T. (2022). Internal crisis communication and Nordic leadership: the importance of transparent and participative communication in times of crisis. *Scandinavian Journal of Hospitality and Tourism*, *22*(4–5), 331–356. <https://doi.org/10.1080/15022250.2022.2123038>
- Hadian Nasab, A., & Afshari, L. (2019). Authentic leadership and employee performance: mediating role of organizational commitment. *Leadership and Organization Development Journal*, *40*(5), 548–560. <https://doi.org/10.1108/LODJ-01-2019-0026>
- Hair, J. F., Matthews, L. M., Matthews, R. L., & Sarstedt, M. (2017). PLS-SEM or CB-SEM: Updated guidelines on which method to use. *International Journal of Multivariate Data Analysis*, *1*(2), 107.
- Hao, L., Zhu, H., He, Y., Duan, J., Zhao, T., & Meng, H. (2022). When Is Silence Golden? A Meta-analysis on Antecedents and Outcomes of Employee Silence. *Journal of Business and Psychology*, *37*(5), 1039–1063. <https://doi.org/10.1007/s10869-021-09788-7>
- Harlos, K., & Knoll, M. (2021). Employee Silence and Workplace Bullying. In *Pathways of Job-related Negative Behaviour. Handbooks of Workplace Bullying, Emotional Abuse and Harassment* (2nd ed.). [https://doi.org/https://doi.org/10.1007/978-981-13-0935-9\\_9](https://doi.org/https://doi.org/10.1007/978-981-13-0935-9_9)
- Jahanzeb, S., Fatima, T., & Malik, M. A. R. (2018). Supervisor ostracism and defensive silence: a differential needs approach. *European Journal of Work and Organizational Psychology*, *27*(4), 430–440. <https://doi.org/10.1080/1359432X.2018.1465411>
- Jeong, Y., & Kim, M. (2022). Effects of perceived organizational support and perceived organizational politics on organizational performance: Mediating role of differential treatment. *Asia Pacific Management Review*, *27*(3), 190–199. <https://doi.org/10.1016/j.apmr.2021.08.002>
- Jha, J. K., & Singh, M. (2019). Exploring the mechanisms of influence of ethical leadership on employment relations. In *IIMB Management Review* (Vol. 31, Issue 4). Elsevier Ltd. <https://doi.org/10.1016/j.iimb.2019.07.010>
- Jiang, H., & Luo, Y. (2018). Article information : Crafting Employee Trust : From Authenticity , Transparency to Engagement. *Journal of Communication Management*, *22*(2), 138–160. <https://doi.org/https://doi.org/10.1108/JCOM-07-2016-0055>
- John, S. P., & Manikandan, K. (2019). Employee Silence : A Meta-Analytic Review. *The International Journal of Indian Psychology*, *7*(1), 354–366. <https://doi.org/10.25215/0701.040>
- Kacmar, K. M., & Baron, R. A. (1999). Organizational politics: the state of the field, links to related processes.

*Personnel and Human Resources Management*, 17(August), 1–39.

Kelly, L. (2023). Authentic Leadership: Roots of the Construct

. In *Mindfulness for Authentic Leadership* (Issue November, pp. 17–52). [https://doi.org/10.1007/978-3-031-34677-4\\_2](https://doi.org/10.1007/978-3-031-34677-4_2)

Khalid, J., & Ahmed, J. (2016). Perceived organizational politics and employee silence: supervisor trust as a moderator. *Journal of the Asia Pacific Economy*, 21(2), 174–195. <https://doi.org/10.1080/13547860.2015.1092279>

Khuwaja, U., Ahmed, K., Abid, G., & Adeel, A. (2020). Leadership and employee attitudes: The mediating role of perception of organizational politics. *Cogent Business and Management*, 7(1). <https://doi.org/10.1080/23311975.2020.1720066>

Kim, M., & Beehr, T. A. (2018). Organization-Based Self-Esteem and Meaningful Work Mediate Effects of Empowering Leadership on Employee Behaviors and Well-Being. *Journal of Leadership and Organizational Studies*, 25(4), 385–398. <https://doi.org/10.1177/1548051818762337>

Kim, Y., Lee, E., Kang, M., & Yang, S. U. (2023). Understanding the Influence of Authentic Leadership and Employee-Organization Relationships on Employee Voice Behaviors in Response to Dissatisfying Events at Work. In *Management Communication Quarterly* (Vol. 37, Issue 1). <https://doi.org/10.1177/08933189221085562>

Koontz, K. (2021). *A Quantitative Study Measuring Organizational Culture Perception in Regard to Authentic Followership* (Issue August).

Lam, L. W., & Xu, A. J. (2019). Power Imbalance and Employee Silence: The Role of Abusive Leadership, Power Distance Orientation, and Perceived Organisational Politics. *Applied Psychology*, 68(3), 513–546. <https://doi.org/10.1111/apps.12170>

Lampaki, A., & Papadakis, V. (2018). The impact of organisational politics and trust in the top management team on strategic decision implementation success: A middle-manager's perspective. *European Management Journal*, 36(5), 627–637. <https://doi.org/10.1016/j.emj.2018.07.005>

Liu, M. (2017). Study on Influence Mechanism of Leader-member Exchange Differences to Team Performance. *Proceedings of the 2016 2nd International Conference on Economy, Management, Law and Education (EMLE 2016)*, 20(Eml 2016), 223–227. <https://doi.org/10.2991/emle-16.2017.51>

Lyubovnikova, J., Legood, A., Turner, N., & Mamakouka, A. (2015). How Authentic Leadership Influences Team Performance: The Mediating Role of Team Reflexivity. *Journal of Business Ethics*, 23(4), 307. <https://doi.org/10.3176/chem.geol.1974.4.04>

MacMahon, J., O'Sullivan, M., Murphy, C., Ryan, L., & MacCurtain, S. (2018). Speaking up or staying silent in bullying situations: the significance of management control. *Industrial Relations Journal*, 49(5–6), 473–491. <https://doi.org/10.1111/irj.12230>

Maximo, N., Stander, M. W., & Coxen, L. (2019). Authentic leadership and work engagement: The indirect effects of psychological safety and trust in supervisors. *SA Journal of Industrial Psychology*, 45, 1–11. <https://doi.org/10.4102/sajip.v45i0.1612>

McCaffery, P. (2018). The Higher Education Manager's Handbook: Effective Leadership and Management in Universities and Colleges: Third edition. In *The Higher Education Manager's Handbook: Effective Leadership and Management in Universities and Colleges: Third edition* (Issue September). <https://doi.org/10.4324/9781351249744>

Meyer, J. P., Allen, N. J., & Smith, C. A. (1993). Commitment to Organizations and Occupations: Extension and Test of a Three-Component Conceptualization. *Journal of Applied Psychology*, 78(4), 538–551. <https://doi.org/10.1037/0021-9010.78.4.538>

Monzani, L., Braun, S., & van Dick, R. (2016). It takes two to tango: The interactive effect of authentic leadership and organizational identification on employee silence intentions. *German Journal of Human Resource Management*, 30(3–4), 246–266. <https://doi.org/10.1177/2397002216649896>

Morrison, E. W. (2014). Employee Voice and Silence. *Annual Review of Organizational Psychology and*

- Organizational Behavior*, 1, 173–197. <https://doi.org/10.1146/annurev-orgpsych-031413-091328>
- Naseer, S., Raja, U., Syed, F., Donia, M. B. L., & Darr, W. (2016). Perils of being close to a bad leader in a bad environment: Exploring the combined effects of despotic leadership, leader member exchange, and perceived organizational politics on behaviors. *Leadership Quarterly*, 27(1), 14–33. <https://doi.org/10.1016/j.leaqua.2015.09.005>
- Nazir, O., & Islam, J. U. (2017). Enhancing organizational commitment and employee performance through employee engagement: An empirical check. *South Asian Journal of Business Studies*, 6(1), 98–114. <https://doi.org/10.1108/SAJBS-04-2016-0036>
- Ntim, C. G., Soobaroyen, T., & Broad, M. J. (2017). Governance structures, voluntary disclosures and public accountability: The case of UK higher education institutions. *Accounting, Auditing and Accountability Journal*, 30(1), 65–118. <https://doi.org/10.1108/AAAJ-10-2014-1842>
- Palladan, A. P. (2018). Moderating Effects of Cyberloafing Activity on Innovative Work Behaviour and Lecturers Job Performance. *International Journal of Advanced Studies in Social Science & Innovation*, 2(1), 28–49. <https://doi.org/10.30690/ijassi.21.03>
- Ribeiro, N., Duarte, A. P., Filipe, R., & Oliveira, R. T. de. (2019). How Authentic Leadership Promotes Individual Creativity : The Mediating Role of Affective Commitment. *Journal of Leadership & Organizational Studies*, 27(2), 1–14. <https://doi.org/10.1177/1548051819842796>
- Ribeiro, N., Duarte, A. P., & Oliveira, R. T. de. (2020). How Authentic Leadership Promotes Individual Creativity: The Mediating Role of Affective Commitment. *Journal of Leadership & Organizational Studies*, 27(2). <https://doi.org/https://doi.org/10.1177/1548051819842796>
- Rubens, A., Schoenfeld, G. A., Schaffer, B. S., & Leah, J. S. (2018). Self-awareness and leadership: Developing an individual strategic professional development plan in an MBA leadership course. *International Journal of Management Education*, 16(1), 1–13. <https://doi.org/10.1016/j.ijme.2017.11.001>
- Ruck, K., Welch, M., & Menara, B. (2017). Employee voice: An antecedent to organisational engagement? *Public Relations Review*, 43(5), 904–914.
- Shaukat, R., & Khurshid, A. (2022). Woes of silence: the role of burnout as a mediator between silence and employee outcomes. *Personnel Review*, 51(5), 1570–1586. <https://doi.org/10.1108/PR-07-2020-0550>
- Sumarmi, S., Qamari, I. N., & Saad, M. S. M. (2023). Organizational Citizenship Behavior Predictors: a Mediation Analysis on Savings and Loan Cooperative. *Journal of Law and Sustainable Development*, 11(4), 1–21. <https://doi.org/10.55908/sdgs.v11i4.614>
- Sumarmi, S., Winarni, T., & Sumarni, M. (2022). Transformational Leadership and Organizational Citizenship Behavior in the COVID-19 Era: Mediating Analysis. *KnE Social Sciences*, 2022, 855–867. <https://doi.org/10.18502/kss.v7i14.12037>
- Sun, Y., & Xia, H. (2018). Research on Perceptions of Organizational Politics and Its Influence on Employee Silence. *Open Journal of Business and Management*, 06(02), 250–264. <https://doi.org/10.4236/ojbm.2018.62018>
- Tijani, O. O., & Okunbanjo, O. I. (2020). Authentic Leadership and Organizational Commitment: Empirical Evidence from Information Technology Industry in Nigeria. *Kelaniya Journal of Management*, 9(2), 55–74. <https://doi.org/10.4038/kjm.v9i2.7590>
- Ullah, S., Hasnain, S. A., Khalid, A., & Aslam, A. (2019). Effects of Perception of Organizational Politics on Employee ' s Well-Being : The Mediating Role of Trust and Interpersonal Conflicts. *European Online Journal of Natural and Social Sciences*, 8(1), 1–14. [http://european-science.com/eojnss\\_proc/article/view/5637](http://european-science.com/eojnss_proc/article/view/5637)
- Vardarlier, P., & Akiner, Ö. (2020). Relationship Between Organizational Commitment and Organizational Silence: A Study in the Insurance Industry. In *The Palgrave Encyclopedia of Strategic Management*. [https://doi.org/10.1057/978-1-349-94848-2\\_739-1](https://doi.org/10.1057/978-1-349-94848-2_739-1)
- Walumbwa, F. O., Avolio, B. J., Gardner, W. L., Wernsing, T. S., & Peterson, S. J. (2008). Authentic leadership: Development and validation of a theory-based measure. *Journal of Management*, 34(1), 89–126. <https://doi.org/10.1177/0149206307308913>
- Wiltshire, J., Bourdage, J. S., & Lee, K. (2014). Honesty-Humility and Perceptions of Organizational Politics in

Predicting Workplace Outcomes. *Journal of Business and Psychology*, 29(2), 235–251.  
<https://doi.org/10.1007/s10869-013-9310-0>

Yamane, T. (1967). *Elementary Sampling Theory* (1st ed.). Prentice Hall.

Zikmund, W., Babin, B., Carr, J., & Griffin, M. (2010). *Business Research Methods* Eight Edition. In *South Western Educ Pub*.

#### 8. Penerimaan artikel revisi oleh editor

**New revision received by Editorial Office (JEM-00364-2024-03)** X

Dear Dr. Sumarmi,

Thank you for revising the paper titled 'Authentic Leadership and Employee Silence Intention: Mediated by Perceptions of Organizational Politics and Organizational Commitment'.  
The following number has been assigned to it: JEM-00364-2024-03.

The Editors will review the paper again and, if necessary, send it back to the Reviewers.  
You will be notified about any further decisions regarding this paper.

Sincerely,  
Monika Eisenhardt, Managing Editor  
-----

Journal of Economics and Management  
University of Economics in Katowice, Poland  
e-mail: [jem.submission@ue.katowice.pl](mailto:jem.submission@ue.katowice.pl)  
website: <https://sciendo.com/journal/JEMUEKAT>; [www.ue.katowice.pl/jem](http://www.ue.katowice.pl/jem)

Editorial System is available here: <https://www.editorialsystem.com/jem/>

#### 9. Revisi tata tulis dari Editor in Chief



**University  
of Economics  
in Katowice**

**Journal of Economics and Management**

ISSN 1732-1948

**Authentic Leadership and Employee Silence Intention: Mediated by  
Perceptions of Organizational Politics and Organizational Commitment**

## Abstract

**Aim/Purpose** – This study examines authentic leadership's influence on employee silence intention, mediated by perceptions of organizational politics and organizational commitment.

**Design/methodology/approach** – Research data was obtained through a survey of 251 lecturers at PGRI universities. The method used to analyze the data was structural equation modeling with AMOS.

**Findings** – The research results show that authentic leadership, perceptions of organizational politics, and organizational commitment have a direct effect on employee silence intention. In addition, Perceptions of organizational politics and organizational commitment mediate the influence of authentic leadership on employee silence intention.

**Research implications/limitations** – The theoretical implications of this study strengthen the theory of authentic leadership by demonstrating its negative influence on employee silence intentions. However, a limitation of this study lies in the potential need for more generalizability of the findings, as the study focused only on higher education, so the results may not fully apply to different industries or cultural contexts.

**Originality/value/contribution** – This research makes a significant contribution by exploring the influence of authentic leadership on employee silence intention. It enriches the literature with empirical findings linking leadership honesty, openness, and transparency to reduced employee silence.

**Keywords:** authentic leadership, perceptions of organizational politics, organizational commitment, employee silence intention

**JEL Classification:** M12, M54, O15

## 10. Introduction

Employees' silence when discussing work-related matters has many consequences for individuals, teams, and organizations (Hao et al., 2022). This is because employees are capital with a central role in organizational activities to mobilize and synergize other resources to achieve predetermined goals. (Eckardt et al., 2021; Febriansyah et al., 2019). In the process of achieving performance, it is not uncommon for problems to arise from interactions between employees and colleagues, as well as employees and leaders. However, employees are reluctant to voice problems that arise in the workplace and tend to ignore these problems (Morrison, 2014). This condition is triggered by a dilemma between considering the short-term interests of the leader, who may view voicing a problem as an act of disloyalty, and the organization's long-term interests, which may experience severe costs due to silence (Monzani et al., 2016).

Employee silence is not only related to problems between employees but also to expressing opinions, even though employees have a lot of knowledge and experience that can be used to improve organizational performance (Shaukat & Khurshid, 2022). Employee silence intention is a failure to convey important information to the authorities, which can cause problems for the organization (John & Manikandan, 2019). Previous studies on employee silence intention used this variable as a predictor, such as the impact on organizational turnover intention Al Muala et al.

(2022), well-being, job attitude, and performance (Hao et al., 2022). Researchers intend to investigate employee silence intention as an outcome and use authentic leadership as a predictor.

*Authentic leadership* is defined Walumbwa et al. (2008) as a pattern of leadership behavior that explains and expands positive psychological abilities and a positive moral atmosphere to develop self-awareness, internal moral outlook, balanced information processing, and transparency of communication with followers. An authentic leader will positively affect organizational performance, and the positive impact of an authentic leader on team performance is more robust among employees with high social capital (Akhtar et al., 2021). The self-regulatory behavior inherent in the authentic leadership process shapes collective team behavior, which emerges in the process of team reflexivity, which in turn predicts team performance positively (Lyubovnikova et al., 2015). It is hoped that the leadership pattern of an authentic leader will reduce employee silence intention among employees. This is because authentic leaders can create a safe and trusting environment where team members can work effectively (Maximo et al., 2019). Studies conducted Abdullah et al. (2022; Guenter et al. (2017) found a negative relationship between authentic leadership and silent behavior. Meanwhile Monzani et al., (2016) use a form of silence behavior at the organizational level, namely Exit, Voice, Neglect, and Loyalty, and found a negative relationship between authentic leadership and exit and neglect. Meanwhile, authentic leadership, Loyalty, and Voice have a positive relationship.

In the social environment today, social politics is developing a lot in society and organizations, which is referred to as organizational politics (Sun & Xia, 2018). Differences in political perceptions in the organization that occur between employees, if not managed well, will have a negative impact on the organizational climate (Naseer et al., 2016). Perceptions of organizational politics refers to the maximization of personal interests by organizational members using methods that are not recognized by the formal rules of the organization to influence the distribution of benefits within the organization (Eldor, 2017; Kacmar & Baron, 1999). Research results show that the negative impact of perceptions of organizational politics in the workplace is exacerbated for employees with lower levels of honesty and humility (Wiltshire et al., 2014). Buchanan (2008), states that negative Perceptions of organizational politics can cause employees to feel insecure or worry about the consequences of expressing dissatisfaction. Employees who feel insecure or worried may be more likely to remain silent rather than risk coming forward (Behtoui et al., 2017). Authentic leadership brings transparency into decision-making so leaders can reduce misunderstandings (Alvesson & Einola, 2019). Additionally, transparency reduces the space for negative perceptions such as favoritism or hidden agendas, often related to office politics (Haavisto & Linge, 2022). As role models, authentic leaders demonstrate anti-political behavior (Fawcett & Corbett, 2018).

Organizational commitment is a crucial link between authentic leadership and employees' silence intention. Organizational commitment, a measure of the degree of employee involvement and participation in the organization Sumarmi et al. (2023), can be fostered by authentic leadership, leading to a decrease in employee silence intention. Authentic leaders, as highlighted by Maximo et al. (2019), tend to exhibit consistent, predictive, and reliable behavior, which helps in building trust and psychological safety among employees. Employees who perceive high levels of honesty and transparency from their leaders are more likely to develop greater respect and dedication to the organization (Jiang & Luo, 2018). This commitment strengthens employee identification with the values and goals of the organization, thereby increasing organizational commitment (Nazir & Islam, 2017).

## 11. Literature review

### 11.1. Authentic leadership and employee silence intention

This exploration will address the relationship between authentic leadership and two critical aspects of employee behavior and perceptions: employee silence intention and perceptions of organizational politics. Leaders who embody authentic leadership, emphasizing honesty, integrity, transparency, and authenticity in their interactions with subordinates Jiang & Luo (2018), create an environment where employees feel more comfortable and are encouraged to discuss the problems or concerns they face openly. This approach is expected to reduce the tendency to remain silent significantly (Kelly, 2023). Employee silence intention often stems from the perceptions that speaking openly is unsafe due to the fear of negative consequences or retaliation from management or co-workers (MacMahon et al., 2018). However, through strong, mutually beneficial relationships with subordinates, an authentic leader can foster an inclusive and supportive work environment. Therefore, robust, authentic leadership is anticipated to reduce employee silence in the organization, leading to a more positive and open workplace.

Based on this explanation, the first hypothesis is formulated as follows:

**H1:** Authentic leadership is negatively related to employee silence intention.

### 11.2. Authentic leadership and perceptions of organizational politics

Authentic leadership, characterized by honesty, consistency, and self-awareness, has a profound impact on employees' perceptions (Jiang & Luo, 2018). This leadership style, rooted in self-awareness and a deep understanding of values, strengths, and weaknesses, fosters a positive work environment (Rubens et al., 2018). Employees under the guidance of authentic leaders often develop more positive perceptions of fairness and transparency within the organization Liu (2017), instilling a sense of hope and optimism in the workplace.

On the other hand, perceptions of organizational politics refer to employees' subjective views regarding the existence of political practices, nepotism, or manipulation of power within the organization (Jeong & Kim, 2022). This condition can cause employee job dissatisfaction because they feel unfair or unappreciated for their achievements or contributions. Organizational political practices can also damage trust between employees, management, and co-workers (Ullah et al., 2019). Authentic leadership emphasizing transparency, honesty, and self-awareness will reduce unethical political practices in organizations. Authentic leaders build a culture where decisions and promotions are based on performance and values, not internal politics or personal relationships.

Based on this explanation, the second hypothesis is formulated as follows:

**H2:** Authentic leadership is negatively related to perceptions of organizational politics.

### 11.3. Authentic leadership and organizational commitment

Avolio & Gardner (2005), Highlight the significant impact of authentic leadership in building trust and commitment among followers, where leaders who demonstrate honesty, integrity, and self-awareness can create an environment where employees feel valued and supported, leading to higher levels of commitment to the organization. Employees in an organization will develop a strong emotional attachment (affective commitment), perceive few costs associated with leaving the organization (continuance commitment), and feel a moral obligation to stay with the organization (normative commitment) (Ahmad, 2018; Palladan, 2018). Therefore, higher levels of authentic leadership are expected to result in higher levels of organizational commitment among employees.

The study Walumbwa et al. (2008) discovered a robust positive correlation between authentic leadership and followers' commitment to the organization. Further studies Hadian Nasab & Afshari, (2019); Ullah et al., (2019) have also confirmed this positive relationship. Drawing from these empirical findings, the third hypothesis is formulated as follows:

**H3:** Authentic leadership is positively related to organizational commitment.

#### **11.4. Perceptions of organizational politics and employee silence intentions**

Perceptions of organizational politics refers to employees' subjective perceptions of political behavior, favoritism, or manipulation of power within the organization (Khuwaja et al., 2020). Lam & Xu (2019), highlights the detrimental effects of perceived organizational politics on employee attitudes and behavior, where employees who perceive higher levels of organizational politics are more likely to experience job dissatisfaction, reduced organizational commitment, and higher stress and turnover intentions. Higher. In addition, Ferris et al., (2007) conducted a meta-analysis that examined the relationship between perceptions of organizational politics and employee silence behavior and revealed a significant positive relationship between perceptions of organizational politics and employee silence intentions. Employees who perceive high levels of organizational politics may remain silent to avoid potential retaliation or ostracism from superiors or coworkers (Jahanzeb et al., 2018).

Perceptions of organizational politics create a work environment characterized by distrust, fear, and uncertainty among employees and trigger employees to remain silent and refrain from expressing their ideas, opinions, or concerns, even when doing so could benefit the organization. Studies Khalid & Ahmed (2016); Sun & Xia (2018), found a positive relationship between perceptions of organizational politics and employee silence. Based on this explanation, hypothesis 4 in this research is as follows.

**H4:** Perceptions of organizational politics are positively related to employee silence intention

#### **11.5. Organizational commitment and employee silence intention**

Organizational commitment is employees' trust, involvement, and loyalty toward the organization (Sumarmi et al., 2022). This statement indicates that the higher a person's level of organizational



commitment, the lower the possibility of showing behavior contrary to the organization's interests, such as remaining silent about potentially detrimental issues (Allen et al., 2017). The silence carried out by employees, including silence in conveying development opinions for the organization, tends to have a negative impact on the organization (Morrison, 2014). Employees who feel attached to the organization and have a high commitment to the organization tend not to remain silent about issues related to the welfare of the organization (Kim et al., 2023). The study Vardarlier & Akiner (2020) also found a negative relationship between organizational commitment and employee silence intention.

Based on the explanation above, the fifth hypothesis is as follows:

**H5:** Organizational commitment is negatively related to employee silence intention

#### **11.6. The mediating effect of perceptions of organizational politics and organizational commitment**

Employees led by authentic leaders tend to have a more positive perceptions of organizational culture Koontz (2021), because it can create a supportive work environment where employees feel heard, appreciated, and encouraged to participate actively. In addition, an organizational culture influenced by authentic leadership will reduce employees' tendency to have political perceptions, thereby reducing employees' reticence to express opinions (Bakari et al., 2018). In an environment like this, employees feel safer to express opinions without fear of negative consequences.

Based on this explanation, the sixth hypothesis is as follows:

**H6:** Perceptions of organizational politics mediate the negative relationship between authentic leadership and employee silence intention.

Apart from the explanation above, the impact of authentic leaders is that employees become more identified with the values and goals of the organization so that they can increase their commitment to the organization (Ribeiro et al., 2019). This arises because leaders represent the values that employees believe in and support. Strong organizational commitment from employees will encourage employees to share information and relevant issues actively rather than remaining silent (Morrison, 2014). Based on this explanation, the seventh hypothesis is formulated as follows:

**H7:** Organizational commitment mediates the negative relationship between authentic leadership and employee silence intention.

The relationship between constructs in the seven hypotheses above is presented in Figure 1. For each construct, indicators are also listed to measure the construct.

#### **Figure 1. Research Model**

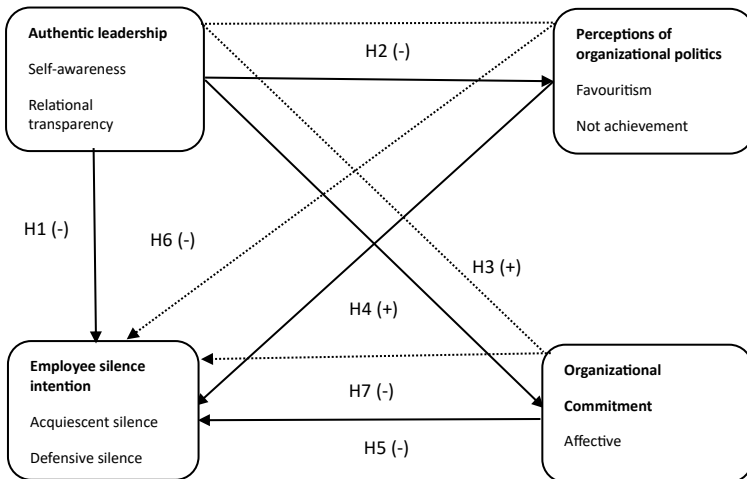

Source: Author's elaboration (2024)

## 12. Research methodology

### 12.1. Sample and Data Collection

Our sampling method was distinct, utilizing a non-probability approach. This means that elements in the population were not uniformly likely to be selected as sample subjects. We employed a purposive sampling technique, a non-probability method where samples are selected based on specific characteristics deemed relevant by the researchers. This approach allows for the targeted selection of individuals who meet particular criteria essential for the study (Zikmund et al., 2010). In this study, we focused on 29 PGRI universities on the island of Java, Indonesia and 251 lecturers as respondents. PGRI is an abbreviation of "Persatuan Guru Republic Indonesia," or the Republic of Indonesia Teachers Association in English. The research was conducted at a university because academics have well-documented policies, and the unique pressures and politics at universities provide insight into how authentic leadership can reduce negative impacts on employee behavior, thereby increasing the generalizability of the findings to other contexts.

The population of this study was 1055 permanent lecturers of the PGRI foundation. Using the Slovin formula (Yamane, 1967) (Yamane, 1967), and calculations using the Slovin calculator and the formula above, the number of samples was 290,034.

Commented [U.1]: Lower letters

Commented [U.2]: Solving?

Commented [U.3]: ?

$$n = \frac{N}{1+N(e)^2} \quad (1)$$

Description:

n = sample size/number of respondents

N = population size

e = percentage of tolerance for sampling error accuracy (Yamane, 1967).

$$n = \frac{1055}{1+1055(0,05)^2} \quad (2)$$

$$n = 290,034 \quad (3)$$

Since this study used 29 universities, the researchers took 10 respondents from each. Because this study used 29 universities, the researcher took 10 respondents from each. After waiting two months, respondents planned to fill out the questionnaire, but only 251 data could be analyzed.

Data collection was carried out using a questionnaire distributed through Google Forms. Before the respondents filled out the questionnaire, the researcher sent a message via personal network to the Vice Chancellor for Human Resource Development to assign lecturers to fill out the questionnaire. This research was conducted from March to May 2024. After waiting two months, the respondents planned to complete the questionnaire, but only 251 data could be analyzed. The educational level of lecturers is 64,9 % have a Master's degree, and 35,1 have a Doctoral degree. Tenure of lecturers at universities < 5 years by 25,5 %; > 5 – 10 years by 35,5 %; > 10 – 15 years by 24,7 %; > 15 – 20 years by 11,9 %; and > 20 years by 2,4 %. Most lecturers' academic positions are Assistant Professor at 47,41 %, Associate Professor at 13,94 %, and Lecturer at 38,65 %.

## 12.2. Measurements

Authentic leadership, a key focus of our study, was measured using developed dimensions (Kelly, 2023; Ribeiro et al., 2020; Walumbwa et al., 2008). These dimensions include Self-awareness, Relational transparency, Balanced processing, and Internalized moral perspective. To provide a clear picture, we included examples of questionnaire items that reflect these dimensions, such as "Leaders always seek feedback to improve interactions with others" and "Leaders listen carefully and consider different points of view before concluding."

Leadership in higher education differs significantly from leadership in companies and corporations due to several unique factors. First, higher education has a more decentralized organizational structure with greater autonomy for each faculty and department (Frølich et al., 2019). This requires a leadership style that accommodates a diversity of opinions and a more collaborative approach. Authentic leadership is particularly relevant in this context because it emphasizes transparency, honesty, and integrity, which can build a safe and trusting environment for faculty to share their ideas and opinions without fear of reprisal (Maximo et al., 2019; Ribeiro et al., 2020). In addition, higher education has a dual mission of teaching, community service, and research that requires a flexible and supportive leadership approach (McCaffery, 2018). Authentic leadership can help create an academic culture that supports innovation and creativity by providing genuine support and recognition to faculty for their contributions (Alzghoul et al., 2018). In academic environments, where collaboration and professional development are highly valued, authentic leadership can increase faculty commitment to the institution and strengthen their involvement in decision-making processes (Elrehail et al., 2017). Finally, political pressures and dynamics in higher

education often differ from those in companies and corporations (Ntim et al., 2017). Authentic leadership that encourages open and honest communication can reduce negative perceptions of organizational politics and increase clarity and fairness in decision-making. Thus, authentic leadership in higher education promotes the psychological health and well-being of faculty and enhances the organization's effectiveness and performance as a whole.

Perception of organizational politics was measured using items developed Ferris & Kacmar (1992); Jeong & Kim (2022); Ullah et al. (2019), namely: Favoritism, not achievement, determines who is superior; you can get along here by being a good person, regardless of the quality of your work; and there are "clusters" or "clusters" that hinder effectiveness here.

Employee silence intention is measured using the dimensions of acquiescent silence, defensive silence, prosocial silence, and opportunistic (Hao et al., 2022; Harlos & Knoll, 2021). One item indicates the extent to which employees remain silent, such as "I prefer to remain silent rather than voice my opinion when faced with phenomena that affect work efficiency."

Organizational Commitment is measured using the dimensions of Nasab & Afshari (2019); Meyer et al., (1993), is affective, continuance, and normative. An example item is, "I feel proud to tell other parties that I am part of the PGRI organization."

In summary, the measurement items are specified in Table 1.

**Table 1.** Constructs and items

Construct	Item	Item Abbreviation
Authentic Leadership	Leaders at our college accurately describe how others view their abilities.	SF- Self awareness
	Leaders always seek feedback to improve interactions with others	RT- Relational transparency
	Leaders at our colleges demonstrate beliefs consistent with action.	BP- Balanced Processing
	Leaders listen carefully and consider different points of view before concluding	IMP- Internalized Moral Perspective
Perceptions of Organizational Politics	The deciding factor for winning here is not merit, but rather favoritism.	F- Favoritism
	Leaders in these organizations frequently employ selection procedures to exclusively recruit individuals who can offer assistance in the future or share similar perspectives.	NP- not achievement
	Success depends on knowing the right people and seeking their help when needed.	A - There are clusters

**Commented [U.4]:** In the Figure 2 is SA, not SF.  
Revise the whole text and Figures, and Tables

	There are always influential groups in these organizations due to gender, regionalism, school ties, and kinship.	G- Being a good person
Organizational Commitment	I stay with this organization because I value loyalty and feel a moral obligation to remain.	AC- Affective commitment
	I feel proud to tell other parties that I am part of the PGRI organization	CC- continuance commitment
	I am eager to commit to a long and successful career with this organization.	NC- Normative commitment
Employee Silence Retention	I believe it might be unsafe to voice my concerns.	AS- Acquiescent silence
	I was concerned that sharing my thoughts and concerns could have a detrimental effect on my professional advancement.	DS- Defensive silence
	To deliberately inflict harm on another individual.	PS- Prosocial silence
	I think expressing my thoughts and worries could potentially hinder my career progression.	OS- Opportunistic Silence

The measurement scale for the four constructs uses a Likert scale of 1 to 5. The measurement scale of the four constructs uses a Likert scale of 1 to 5. For authentic leadership and organizational commitment, Scale 1 means Strongly disagree, Scale 2 disagree, Scale 3 neutral, Scale 4 agree, and Scale 5 means strongly agree. Perception of organizational politics and employee silence intention means the opposite, where scale 1 means Strongly agree, scale 2 agree, scale 3 neutral, Scale 4 disagree, and Scale 5 means strongly disagree.

Commented [U.5]: Two the same sentences

### 12.3. Data analysis technique

Research data analysis began by testing the validity of the factorial structure, which was carried out through the use of confirmatory factor analysis (CFA) within a structural equation modeling (SEM) framework (Byrne, 2001). The hypothesis was tested using structural equation modeling, and the researcher used CB-SEM AMOS.

### 13. Research findings

The initial research stage was conducted by testing the instrument through reliability and construct validity. Based on the results of data analysis, the estimated Standardized Regression Weight value for all statement items is above 0,5, as presented in Table 2. This obtained value can be interpreted if all questionnaire items are declared valid. The reliability test can be determined from the CR and AVE values presented in Table 2. From the calculation results, the CR value is above 0,9, and the AVE value is above 0,5, so all questionnaire items are also declared reliable.

Commented [U.6]: There is a decimal point in English, not a comma.

Revise the whole text, Tables and Figures

Table 2. Construct reliability and validity

Constructs	Items	Loading factors	Cronbach alpha	CR	AVE
Authentic_Leadership	SF	0,721	0,910	0,91	0,71
	RT	0,915			
	BP	0,911			
	IMP	0,853			
Perceptions of Organizational Politics	F	0,705	0,919	0,91	0,71
	NP	0,907			
	A	0,921			
	G	0,816			
Organizational Commitment	AC	0,814	0,902	0,92	0,8
	CC	0,948			
	NC	0,916			
Employee Silence Retention	AS	0,952	0,899	0,89	0,69
	DS	0,942			
	PS	0,711			
	OS	0,677			

Commented [U.7]: ? SF or SA

Source: processed primary data (2024)

The HTMT criterion for discriminant validity of first-order constructs, as suggested by (Hair et al., 2017), should not surpass 0,9. In the pairwise comparisons presented in Table 3, the HTMT value did not go beyond 0,9, thus confirming discriminant validity.

Table 2. Discriminant validity Heterotrait – monotrait ration (HTMT) results

Constructs	Authentic leadership	Organizational commitments	Employee silence intention
Authentic leadership			
Organizational commitment	0,792		
Employee silence intention	0,841	0,893	
Perceptions of organizational politics	0,826	0,810	0,851

Source: processed primary data (2024)

After all statement items are declared valid and reliable, a full research model analysis is carried out to test the hypothesis. The results of the hypothesis testing are presented in Figure 2, Table 3, and Table 4.

Figure 2: Full Model Analysis

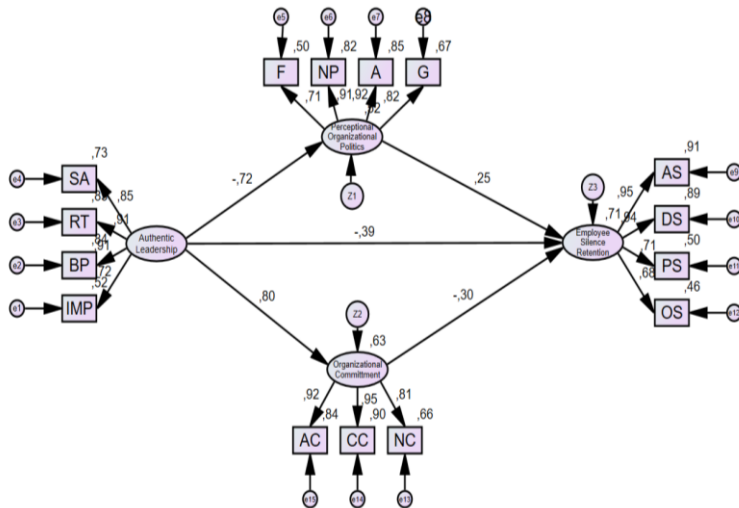

Commented [U.8]: Lower case letters

Note: SA: Self-awareness, RT: Relational transparency, BP: Balanced processing, IMP: Internalized moral perspective, F: Favoritism, NP: Not achievement, G: Being a good person, A: There are clusters, AC: Affective commitment, CC: Continuance commitment, NC: Normative commitment, AS: Acquiescent silence, DS: Defensive silence, PS: Prosocial silence, and OS: Opportunistic silence.

Commented [U.9]: ?

Based on the data analysis results in Table 3, the p-value obtained from the direct relationship between the constructs tested in hypotheses 1 – 5 is 0,000, with a statistical t-value greater than 1,96. These results show that the direct influence on hypotheses 1 – 5 is proven to be significant, so this hypothesis is supported by the research results.

Table 3. Direct Effect Hypothesis Test Results

Direct effect	Estimate	S.E.	CR	P	Decision
H1: Authentic Leadership and Perceptions_Organizational_Politics	-.833	,085	9,755	0,000	Supported
H2: Authentic Leadership and Organizational Commitment	,840	,080	10,469	0,000	Supported
H3: Perceptions_Organizational_Politics and Employee_Silence_Retention	,229	,079	2,902	0,004	Supported
H4: Organizational Commitment and Employee_Silence_Retention	-.295	,131	2,248	0,025	Supported
H5: Authentic Leadership and Employee_Silence_Retention	-.407	,134	3,028	0,003	Supported

Commented [U.10]: Lower case letters

Source: processed primary data (2024)

Table 4 shows the output of the indirect effect analysis, where perceptions of organizational politics and organizational commitment mediate the influence of authentic leadership and employee silence intention. The p-value of the indirect relationship between authentic leadership and employee silence intention is 0,000, with a t-statistic value greater than 1,96. Likewise, the p-value of authentic leadership and employee silence intention is mediated by organizational commitment. These results indicate that the indirect effect on hypotheses 6 and 7 is significant, so the study's results support this hypothesis.

Table 4. Indirect Effect Hypothesis Test Results

Indirect effect	Estimate	S.E.	CR	P	Decision
-----------------	----------	------	----	---	----------

Commented [U.11]: Lower case letters

H6: Perceptions of organizational politics mediate authentic leadership and employee silence intention.	-,190	,068	2,815	0,005	Supported
H7: Organizational commitment mediates authentic leadership and employee silence intention.	-0,247	,116	2,133	0,033	Supported

Source: processed primary data (2024)

### 13. Discussion

The finding of the first hypothesis, where authentic leadership negatively influences employee silence intention, adds to the empirical findings of studies conducted (Abdillah et al., 2022; Guenter et al., 2017; Monzani et al., 2016). Based on the study findings, authentic leadership is necessary for creating a positive and productive work environment through openness, trust, and involvement, reducing employees' tendency to remain silent and encouraging more significant contributions from all team members. When employees perceive their leaders as honest and transparent, trust in them increases, reducing their apprehension about potential negative consequences when expressing their opinions (Agote et al., 2016). Employees are likelier to speak up and participate actively in discussions and decision-making. These conditions not only improve the organization's overall health but also encourage innovation and continuous improvement.

The second hypothesis is also supported by research results, where Authentic Leadership also negatively influences Perception of Organizational Politics. Authentic leaders consistently behave honestly and openly, which helps reduce suspicion and perceptions of manipulation among employees (Alvesson & Einola, 2019). When employees see that their leaders operate with integrity, their trust in the organization increases, and perceptions of organizational politics decrease (Lampaki & Papadakis, 2018). Authentic leaders also ensure that decisions are made based on fair and transparent principles, not favoritism or hidden agendas, which helps reduce the perception that political actions dominate the organization. Employees are encouraged to convey their ideas, input, and concerns without fear of reprisal or manipulation. They will create a culture where every voice is valued and considered, reducing perceptions of organizational politics (Alavi & Gill, 2016). Employee engagement increases when they feel valued and heard. Authentic leadership will help create an environment where employees feel motivated to contribute positively without getting involved in organizational politics to get ahead.

This study also proves the third hypothesis that authentic leadership positively affects organizational commitment. This study is in line with the findings of Tijani & Okunbanjo (2020), which also found a positive influence between these two variables. Honesty and transparency, emphasized in authentic leadership, will build trust between leaders and employees. When employees believe that their leaders are honest and consistent, it will create a greater sense of psychological security (Maximo et al., 2019), and this sense of security increases employees' emotional attachment (affective commitment) to the organization (Camgoz & Karapinar, 2016). Authentic leaders encourage employees to participate actively in the decision-making process and share ideas and input so that employees feel valued. A sense of appreciation makes employees more emotionally and normatively committed to the organization (Morrison, 2014).



The fourth hypothesis is also substantiated by the research, revealing that Perceptions of Organizational Politics has a detrimental effect on employee silence intention. The high perception of organizational politics among employees often instills fear of negative consequences if they voice their opinions (Morrison, 2014). Employees are concerned that expressing their views could jeopardize their position, influence performance evaluations, or make them vulnerable to retaliation by powerful individuals within the organization (Bashshur & Oc, 2015; Brinsfield, 2012). This situation breeds apathy and a reluctance to be actively involved, leading employees to choose silence. They withdraw and opt not to voice their opinions, believing that it will not positively impact their future careers.

The fifth hypothesis produces the finding that organizational commitment negatively influences employee silence intention. Employees with high commitment to the organization are emotionally attached to the organization. This attachment creates a sense of ownership and responsibility to contribute positively. It is happy to voice opinions based on concern for the success and welfare of the organization (Kim & Beehr, 2018). Employees feel that employee voices are essential for organizational development and will be heard, so they tend to reduce their intention to remain silent (Ruck et al., 2017). Moreover, with high commitment, employees have a greater sense of trust in the organization and its leaders. Employees feel safe to express their opinions without fear of negative consequences.

The study's results also support the test of the indirect effect of authentic leadership on employee silence intention mediated by dynamic adaptive capability and authentic leadership on employee silence intention mediated by organizational commitment. Perception of organizational politics is proven to mediate the negative influence of authentic leadership on employee silence intention. The findings highlight the complexity of organizational dynamics. Honest and open leaders tend to create a work environment where employees feel safe and can voice opinions without fear of negative repercussions (Jha & Singh, 2019). This honesty and openness directly reduce employee intentions to remain silent. However, authentic leadership is essential, and reducing perceptions of politics within the organization is crucial in encouraging open communication and reducing employee intentions to remain silent (Kim et al., 2023). Even in organizations with authentic leadership, employees may remain hesitant to voice their opinions if they perceive a high level of organizational politics. It is based on the idea that open communication will not be protected or valued in an environment dominated by organizational politics. Therefore, organizations must work proactively to create a transparent, fair, and supportive work environment to achieve these goals (Chang et al., 2022).

The finding that organizational commitment mediates the negative influence of authentic leadership on employees' intention to remain silent underscores the importance of fostering strong and committed relationships between employees and the organization. This finding reiterates the main message of the research, which is that authentic leadership not only promotes openness and trust in the workplace but also strengthens employee commitment, thereby reducing their tendency to remain silent. The research suggests that organizations should focus on developing authentic leadership and commitment-enhancing strategies to create a more open and productive work environment. This, in turn, encourages employees to speak up and share their ideas for the benefit of the organization, thereby reinforcing the importance of the research findings.

## **14. Conclusions**

This study confirms that authentic leadership hurts employees' intention to remain silent, and perceptions of organizational politics and organizational commitment mediate this effect. Authentic leadership characterized by honesty, openness, and transparency can create a more positive, productive, and politically free work environment, reducing employees' tendency to remain silent. In addition, employees who feel valued and trust their leaders tend to be more committed to the university and are more courageous in voicing their opinions.

The theoretical implications of this research strengthen authentic leadership theory by adding empirical evidence about its negative influence on employee intentions to remain silent. This implication shows that authentic leadership influences employee performance and well-being and plays an essential role in reducing employee silence. It also adds to the literature on organizational politics by showing that authentic leadership can reduce perceptions of organizational politics, reducing employee intentions to remain silent. This study expands the understanding of how organizational commitment mediates the relationship between authentic leadership and employees' silence intention to remain silent, suggesting that increasing employee commitment can play an essential role in creating a more open and collaborative work environment.

The practical implications of this study are clear. Universities should prioritize leadership development through training programs emphasizing honesty, transparency, and openness. Additionally, management should actively seek to reduce organizational politics by implementing fair and transparent policies and avoiding favoritism. These steps are crucial to creating a healthier and more open work environment.

It is essential to note the limitations of this study. The findings, while significant, may only be universally applicable to some industries or cultures. Therefore, further research is needed to validate the findings in different contexts, ensuring the robustness and reliability of the study's conclusions.

Suggestions for future research include contextual studies. Conducting research across industries and cultures can strengthen the generalizability of these findings and help understand how context influences these relationships. Further research could explore additional mediator or moderator variables that may influence these relationships, such as organizational culture, psychological climate, and communication style.

#### **15. Declaration of competing interest**

The author declares that there is no potential conflict of interest.

#### **16. Funding**

The research was supported by xxxxxxxxx (should be added after review)

#### **References (Times New Roman, 12-point, bold, left aligned, line spacing: single)**

- Abdillah, M. R., Anita, R., Agusanto, A., & Rahmat, A. (2022). Authentic Leader and Employee's Silence Behavior: Testing a Happiness at Work Mechanism. *INOBI: Jurnal Inovasi Bisnis Dan Manajemen Indonesia*, 5(4), 443–460. <https://doi.org/10.31842/jurnalnobis.v5i4.243>
- Agote, L., Aramburu, N., & Lines, R. (2016). Authentic Leadership Perception, Trust in the Leader, and Followers' Emotions in Organizational Change Processes. *Journal of Applied Behavioral Science*, 52(1), 35–63.

<https://doi.org/10.1177/0021886315617531>

- Ahmad, A. (2018). The relationship among job characteristics organizational commitment and employee turnover intentions: A reciprocation perspective. *Journal of Work-Applied Management*, 10(1), 74–92. <https://doi.org/10.1108/JWAM-09-2017-0027>
- Akhtar, M. W., Aslam, M. K., Huo, C., Akbar, M., Afzal, M. U., & Rafiq, M. H. (2021). The interplay of authentic leadership and social capital on team leader performance in public and private sector universities. *Kybernetes*, 1. <https://doi.org/10.1108/K-06-2021-0446>
- Al Mualla, I., Al-Ghalabi, R. R., Alsheikh, G. A. A., Hamdan, K. B., & Alnawafleh, E. A. T. (2022). Evaluating the Effect of Organizational Justice on Turnover Intention in the Public Hospitals of Jordan: Mediated-Moderated Model of Employee Silence, Workplace Bullying, and Work Stress. *International Journal of Professional Business Review*, 7(3), 1–23. <https://doi.org/10.26668/businessreview/2022.v7i3.0526>
- Alavi, S. B., & Gill, C. (2016). Leading Change Authentically : How Authentic Leaders Influence Follower Responses to Complex Change. *Journal of Leadership & Organizational Studies*, 24(2), 1–15. <https://doi.org/10.1177/1548051816664681>
- Allen, D. G., Pelkotorpi, V., & Rubenstein, A. L. (2017). When “embedded” means “stuck” : moderating effects of job embeddedness in adverse work environments. *Journal of Applied Psychology*, 101(2016), 1670–1686.
- Alvesson, M., & Einola, K. (2019). Warning for excessive positivity: Authentic leadership and other traps in leadership studies. *Leadership Quarterly*, 30(4), 383–395. <https://doi.org/10.1016/j.leaqua.2019.04.001>
- Alzghoul, A., Elrehail, H., Emeagwali, O. L., & AlShboul, M. K. (2018). Knowledge management, workplace climate, creativity and performance: The role of authentic leadership. *Journal of Workplace Learning*, 30(8), 592–612. <https://doi.org/10.1108/JWL-12-2017-0111>
- Avolio, B. J., & Gardner, W. L. (2005). Authentic leadership development: Getting to the root of positive forms of leadership. *Leadership Quarterly*, 16(3), 315–338. <https://doi.org/10.1016/j.leaqua.2005.03.001>
- Bakari, H., Hunjra, A. I., Shabbir, G., & Niazi, K. (2018). How Does Authentic Leadership Influence Planned Organizational Change ? The Role of Employees ' Perceptions : Integration of Theory of Planned Behavior and Lewin ' s Three Step Model. *Journal of Change Management*, 17(2), 1–33. <https://doi.org/10.1080/14697017.2017.1299370>
- Bashshur, M. R., & Oc, B. (2015). When Voice Matters: A Multilevel Review of the Impact of Voice in Organizations. *Journal of Management*, 41(5), 1530–1554. <https://doi.org/10.1177/0149206314558302>
- Behtoui, A., Boréus, K., Neergaard, A., & Yazdanpanah, S. (2017). Speaking up, leaving or keeping silent: Racialized employees in the Swedish elderly care sector. *Work, Employment and Society*, 31(6), 954–971. <https://doi.org/10.1177/0950017016667042>
- Brinsfield, C. T. (2012). Employee silence Motives: Investigation of diemnsionality and development of measures. *Journal of Organizational Behavior*, 60(1), 5–22. <https://doi.org/10.1002/job.1829>
- Buchanan, D. A. (2008). You stab my back, I'll stab yours: Management experience and perceptions of organization political behaviour. *British Journal of Management*, 19(1), 49–64. <https://doi.org/10.1111/j.1467-8551.2007.00533.x>
- Byrne, B. M. (2001). Structural Equation Modeling With AMOS , EQS , and LISREL : Comparative Approaches to Testing for the Factorial Validity of a Measuring Instrument. *International Journal of Testing*, 1(1), 55–86.
- Camgoz, S. M., & Karapinar, P. B. (2016). Linking secure attachment to commitment: trust in supervisors. *Leadership & Organization Development Journal*, 34(1), 1–5.
- Chang, P. C., Ma, G., & Lin, Y. Y. (2022). Inclusive Leadership and Employee Proactive Behavior: A Cross-Level Moderated Mediation Model. *Psychology Research and Behavior Management*, 15, 1797–1808. <https://doi.org/10.2147/PRBM.S363434>
- Eckardt, R., Tsai, C. Y., Dionne, S. D., Dunne, D., Spain, S. M., Park, J. W., Cheong, M., Kim, J., Guo, J., Hao, C., & Kim, E. Il. (2021). Human capital resource emergence and leadership. *Journal of Organizational Behavior*, 42(2), 269–295. <https://doi.org/10.1002/job.2446>
- Eldor, L. (2017). Looking on the Bright Side: The Positive Role of Organisational Politics in the Relationship between Employee Engagement and Performance at Work. *Applied Psychology*, 66(2), 233–259.

<https://doi.org/10.1111/apps.12090>

- Elrehail, H., Emeagwali, O. L., Alsaad, A., & Alzghoul, A. (2017). The Impact of Transformational and Authentic Leadership on Innovation in Higher Education : The Contingent Role of Knowledge Sharing. *Telematics and Informatics*. <https://doi.org/10.1016/j.tele.2017.09.018>
- Fawcett, P., & Corbett, J. (2018). Politicians, professionalization and anti-politics: why we want leaders who act like professionals but are paid like amateurs. *Policy Sciences*, *51*(4), 411–432. <https://doi.org/10.1007/s11077-018-9323-7>
- Febriansyah, Sumarmi, S., & Haryono, S. (2019). Pengaruh Kepemimpinan, Kemampuan Kerja Terhadap Kinerja Pegawai Dinas Pendidikan Provinsi Sumsel Dimediasi Motivasi Kerja. *Jurnal Ekonomi Manajemen Sumber Daya*, *22*(1), 21–28. <https://journals.ums.ac.id/index.php/dayasaing/article/view/10704>
- Ferris, G. R., & Kacmar, K. M. (1992). Perceptions of Organizational Politics. *Journal of Management*, *18*(1), 93–116.
- Ferris, G. R., Treadway, D. C., Perrewé, P. L., Brouer, R. L., Douglas, C., & Lux, S. (2007). Political skill in organizations. *Journal of Management*, *33*(3), 290–320. <https://doi.org/10.1177/0149206307300813>
- Frølich, N., Christensen, T., & Stensaker, B. (2019). Strengthening the strategic capacity of public universities: The role of internal governance models. *Public Policy and Administration*, *34*(4), 475–493. <https://doi.org/10.1177/0952076718762041>
- Gunter, H., Schreurs, B., van Emmerik, I. H., & Sun, S. (2017). What Does it Take to Break the Silence in Teams: Authentic Leadership and/or Proactive Followership? *Applied Psychology*, *66*(1), 49–77. <https://doi.org/10.1111/apps.12076>
- Haavisto, V. E., & Linge, T. T. (2022). Internal crisis communication and Nordic leadership: the importance of transparent and participative communication in times of crisis. *Scandinavian Journal of Hospitality and Tourism*, *22*(4–5), 331–356. <https://doi.org/10.1080/15022250.2022.2123038>
- Hadian Nasab, A., & Afshari, L. (2019). Authentic leadership and employee performance: mediating role of organizational commitment. *Leadership and Organization Development Journal*, *40*(5), 548–560. <https://doi.org/10.1108/LODJ-01-2019-0026>
- Hair, J. F., Matthews, L. M., Matthews, R. L., & Sarstedt, M. (2017). PLS-SEM or CB-SEM: Updated guidelines on which method to use. *International Journal of Multivariate Data Analysis*, *1*(2), 107.
- Hao, L., Zhu, H., He, Y., Duan, J., Zhao, T., & Meng, H. (2022). When Is Silence Golden? A Meta-analysis on Antecedents and Outcomes of Employee Silence. *Journal of Business and Psychology*, *37*(5), 1039–1063. <https://doi.org/10.1007/s10869-021-09788-7>
- Harlos, K., & Knoll, M. (2021). Employee Silence and Workplace Bullying. In *Pathways of Job-related Negative Behaviour. Handbooks of Workplace Bullying, Emotional Abuse and Harassment* (2nd ed.). [https://doi.org/https://doi.org/10.1007/978-981-13-0935-9\\_9](https://doi.org/https://doi.org/10.1007/978-981-13-0935-9_9)
- Jahanzeb, S., Fatima, T., & Malik, M. A. R. (2018). Supervisor ostracism and defensive silence: a differential needs approach. *European Journal of Work and Organizational Psychology*, *27*(4), 430–440. <https://doi.org/10.1080/1359432X.2018.1465411>
- Jeong, Y., & Kim, M. (2022). Effects of perceived organizational support and perceived organizational politics on organizational performance: Mediating role of differential treatment. *Asia Pacific Management Review*, *27*(3), 190–199. <https://doi.org/10.1016/j.apmr.2021.08.002>
- Jha, J. K., & Singh, M. (2019). Exploring the mechanisms of influence of ethical leadership on employment relations. In *IIMB Management Review* (Vol. 31, Issue 4). Elsevier Ltd. <https://doi.org/10.1016/j.iimb.2019.07.010>
- Jiang, H., & Luo, Y. (2018). Article information : Crafting Employee Trust : From Authenticity , Transparency to Engagement. *Journal of Communication Management*, *22*(2), 138–160. <https://doi.org/https://doi.org/10.1108/JCOM-07-2016-0055>
- John, S. P., & Manikandan, K. (2019). Employee Silence : A Meta-Analytic Review. *The International Journal of Indian Psychology*, *7*(1), 354–366. <https://doi.org/10.25215/0701.040>
- Kacmar, K. M., & Baron, R. A. (1999). Organizational politics: the state of the field, links to related processes.

*Personnel and Human Resources Management*, 17(August), 1–39.

Kelly, L. (2023). Authentic Leadership: Roots of the Construct

. In *Mindfulness for Authentic Leadership* (Issue November, pp. 17–52). [https://doi.org/10.1007/978-3-031-34677-4\\_2](https://doi.org/10.1007/978-3-031-34677-4_2)

Khalid, J., & Ahmed, J. (2016). Perceived organizational politics and employee silence: supervisor trust as a moderator. *Journal of the Asia Pacific Economy*, 21(2), 174–195. <https://doi.org/10.1080/13547860.2015.1092279>

Khuwaja, U., Ahmed, K., Abid, G., & Adeel, A. (2020). Leadership and employee attitudes: The mediating role of perception of organizational politics. *Cogent Business and Management*, 7(1). <https://doi.org/10.1080/23311975.2020.1720066>

Kim, M., & Beehr, T. A. (2018). Organization-Based Self-Esteem and Meaningful Work Mediate Effects of Empowering Leadership on Employee Behaviors and Well-Being. *Journal of Leadership and Organizational Studies*, 25(4), 385–398. <https://doi.org/10.1177/1548051818762337>

Kim, Y., Lee, E., Kang, M., & Yang, S. U. (2023). Understanding the Influence of Authentic Leadership and Employee-Organization Relationships on Employee Voice Behaviors in Response to Dissatisfying Events at Work. In *Management Communication Quarterly* (Vol. 37, Issue 1). <https://doi.org/10.1177/08933189221085562>

Koontz, K. (2021). *A Quantitative Study Measuring Organizational Culture Perception in Regard to Authentic Followership* (Issue August).

Lam, L. W., & Xu, A. J. (2019). Power Imbalance and Employee Silence: The Role of Abusive Leadership, Power Distance Orientation, and Perceived Organisational Politics. *Applied Psychology*, 68(3), 513–546. <https://doi.org/10.1111/apps.12170>

Lampaki, A., & Papadakis, V. (2018). The impact of organisational politics and trust in the top management team on strategic decision implementation success: A middle-manager's perspective. *European Management Journal*, 36(5), 627–637. <https://doi.org/10.1016/j.emj.2018.07.005>

Liu, M. (2017). Study on Influence Mechanism of Leader-member Exchange Differences to Team Performance. *Proceedings of the 2016 2nd International Conference on Economy, Management, Law and Education (EMLE 2016)*, 20(Emle 2016), 223–227. <https://doi.org/10.2991/emle-16.2017.51>

Lyubovnikova, J., Legood, A., Turner, N., & Mamakouka, A. (2015). How Authentic Leadership Influences Team Performance: The Mediating Role of Team Reflexivity. *Journal of Business Ethics*, 23(4), 307. <https://doi.org/10.3176/chem.geol.1974.4.04>

MacMahon, J., O'Sullivan, M., Murphy, C., Ryan, L., & MacCurtain, S. (2018). Speaking up or staying silent in bullying situations: the significance of management control. *Industrial Relations Journal*, 49(5–6), 473–491. <https://doi.org/10.1111/irj.12230>

Maximo, N., Stander, M. W., & Coxen, L. (2019). Authentic leadership and work engagement: The indirect effects of psychological safety and trust in supervisors. *SA Journal of Industrial Psychology*, 45, 1–11. <https://doi.org/10.4102/sajip.v45i0.1612>

McCaffery, P. (2018). The Higher Education Manager's Handbook: Effective Leadership and Management in Universities and Colleges: Third edition. In *The Higher Education Manager's Handbook: Effective Leadership and Management in Universities and Colleges: Third edition* (Issue September). <https://doi.org/10.4324/9781351249744>

Meyer, J. P., Allen, N. J., & Smith, C. A. (1993). Commitment to Organizations and Occupations: Extension and Test of a Three-Component Conceptualization. *Journal of Applied Psychology*, 78(4), 538–551. <https://doi.org/10.1037/0021-9010.78.4.538>

Monzani, L., Braun, S., & van Dick, R. (2016). It takes two to tango: The interactive effect of authentic leadership and organizational identification on employee silence intentions. *German Journal of Human Resource Management*, 30(3–4), 246–266. <https://doi.org/10.1177/2397002216649896>

Morrison, E. W. (2014). Employee Voice and Silence. *Annual Review of Organizational Psychology and*

*Organizational Behavior*, 1, 173–197. <https://doi.org/10.1146/annurev-orgpsych-031413-091328>

- Naseer, S., Raja, U., Syed, F., Donia, M. B. L., & Darr, W. (2016). Perils of being close to a bad leader in a bad environment: Exploring the combined effects of despotic leadership, leader member exchange, and perceived organizational politics on behaviors. *Leadership Quarterly*, 27(1), 14–33. <https://doi.org/10.1016/j.leaqua.2015.09.005>
- Nazir, O., & Islam, J. U. (2017). Enhancing organizational commitment and employee performance through employee engagement: An empirical check. *South Asian Journal of Business Studies*, 6(1), 98–114. <https://doi.org/10.1108/SAJBS-04-2016-0036>
- Ntim, C. G., Soobaroyen, T., & Broad, M. J. (2017). Governance structures, voluntary disclosures and public accountability: The case of UK higher education institutions. *Accounting, Auditing and Accountability Journal*, 30(1), 65–118. <https://doi.org/10.1108/AAAJ-10-2014-1842>
- Palladan, A. P. (2018). Moderating Effects of Cyberloafing Activity on Innovative Work Behaviour and Lecturers Job Performance. *International Journal of Advanced Studies in Social Science & Innovation*, 2(1), 28–49. <https://doi.org/10.30690/ijassi.21.03>
- Ribeiro, N., Duarte, A. P., Filipe, R., & Oliveira, R. T. de. (2019). How Authentic Leadership Promotes Individual Creativity : The Mediating Role of Affective Commitment. *Journal of Leadership & Organizational Studies*, 27(2), 1–14. <https://doi.org/10.1177/1548051819842796>
- Ribeiro, N., Duarte, A. P., & Oliveira, R. T. de. (2020). How Authentic Leadership Promotes Individual Creativity: The Mediating Role of Affective Commitment. *Journal of Leadership & Organizational Studies*, 27(2). <https://doi.org/https://doi.org/10.1177/1548051819842796>
- Rubens, A., Schoenfeld, G. A., Schaffer, B. S., & Leah, J. S. (2018). Self-awareness and leadership: Developing an individual strategic professional development plan in an MBA leadership course. *International Journal of Management Education*, 16(1), 1–13. <https://doi.org/10.1016/j.ijme.2017.11.001>
- Ruck, K., Welch, M., & Menara, B. (2017). Employee voice: An antecedent to organisational engagement? *Public Relations Review*, 43(5), 904–914.
- Shaukat, R., & Khurshid, A. (2022). Woes of silence: the role of burnout as a mediator between silence and employee outcomes. *Personnel Review*, 51(5), 1570–1586. <https://doi.org/10.1108/PR-07-2020-0550>
- Sumarmi, S., Qamari, I. N., & Saad, M. S. M. (2023). Organizational Citizenship Behavior Predictors: a Mediation Analysis on Savings and Loan Cooperative. *Journal of Law and Sustainable Development*, 11(4), 1–21. <https://doi.org/10.55908/sdgs.v11i4.614>
- Sumarmi, S., Winarni, T., & Sumarni, M. (2022). Transformational Leadership and Organizational Citizenship Behavior in the COVID-19 Era: Mediating Analysis. *KnE Social Sciences*, 2022, 855–867. <https://doi.org/10.18502/kss.v7i14.12037>
- Sun, Y., & Xia, H. (2018). Research on Perceptions of Organizational Politics and Its Influence on Employee Silence. *Open Journal of Business and Management*, 06(02), 250–264. <https://doi.org/10.4236/ojbm.2018.62018>
- Tijani, O. O., & Okunbanjo, O. I. (2020). Authentic Leadership and Organizational Commitment: Empirical Evidence from Information Technology Industry in Nigeria. *Kelaniya Journal of Management*, 9(2), 55–74. <https://doi.org/10.4038/kjm.v9i2.7590>
- Ullah, S., Hasnain, S. A., Khalid, A., & Aslam, A. (2019). Effects of Perception of Organizational Politics on Employee ' s Well-Being : The Mediating Role of Trust and Interpersonal Conflicts. *European Online Journal of Natural and Social Sciences*, 8(1), 1–14. [http://european-science.com/eojnss\\_proc/article/view/5637](http://european-science.com/eojnss_proc/article/view/5637)
- Vardarlier, P., & Akiner, Ö. (2020). Relationship Between Organizational Commitment and Organizational Silence: A Study in the Insurance Industry. In *The Palgrave Encyclopedia of Strategic Management*. [https://doi.org/10.1057/978-1-349-94848-2\\_739-1](https://doi.org/10.1057/978-1-349-94848-2_739-1)
- Walumbwa, F. O., Avolio, B. J., Gardner, W. L., Wernsing, T. S., & Peterson, S. J. (2008). Authentic leadership: Development and validation of a theory-based measure. *Journal of Management*, 34(1), 89–126. <https://doi.org/10.1177/0149206307308913>
- Wiltshire, J., Bourdage, J. S., & Lee, K. (2014). Honesty-Humility and Perceptions of Organizational Politics in

Predicting Workplace Outcomes. *Journal of Business and Psychology*, 29(2), 235–251.  
<https://doi.org/10.1007/s10869-013-9310-0>

Yamane, T. (1967). *Elementary Sampling Theory* (1st ed.). Prentice Hall.

Zikmund, W., Babin, B., Carr, J., & Griffin, M. (2010). *Business Research Methods* Eight Edition. In *South Western Educ Pub.*

10. Penulis mengirimkan Kembali artikel yang sudah direvisi

11. Jawaban dari Editor in Chief jika artikel Accepted untuk dipublikasi.

Decision: **Initial accept**

Dear Dr. Sumarmi,

We deeply appreciate the effort you've invested in substantially improving the paper according to the requirements of the reviewers and Editors. I am pleased to inform you that your paper, Authentic Leadership and Employee Silence Intention: Mediated by Perceptions of Organizational Politics and Organizational Commitment (JEM-00364-2024-04) has now been initially accepted for publication in JEM, pending the fulfilment of the requirements outlined below.

Please upload the final version of your paper and the Declaration of Copyright in two separate sections.

See [https://www.editorialsystem.com/jem/article/445839/files\\_requested/](https://www.editorialsystem.com/jem/article/445839/files_requested/)

1. Section: Final version with personal data

Upload the final version of your paper, ensuring it includes:

- Complete author names, affiliations, and ORCID (refer to the proper format on the JEM webpage <https://sciendo.com/issue/JEMUEKAT/44/1>)
- Completed the Funding section, if needed
- Completed the Acknowledgement section, if needed
- All corrections accepted and any coloured parts in the body text removed
- Ensure the paper adheres to JEM rules. Guidelines can be found: [https://sciendo-parsed-data-feed.s3.eu-central-](https://sciendo-parsed-data-feed.s3.eu-central-1.amazonaws.com/JEMUEKAT/Instructions_for_Authors.pdf)

[1.amazonaws.com/JEMUEKAT/Instructions\\_for\\_Authors.pdf](https://sciendo-parsed-data-feed.s3.eu-central-1.amazonaws.com/JEMUEKAT/Instructions_for_Authors.pdf)

2. Section: Only for Editors

Upload the scanned and signed by the corresponding author Declaration of Copyright available at:

[https://sciendo-parsed-data-feed.s3.eu-central-](https://sciendo-parsed-data-feed.s3.eu-central-1.amazonaws.com/JEMUEKAT/Declaration_of_Copyright.pdf)

[1.amazonaws.com/JEMUEKAT/Declaration\\_of\\_Copyright.pdf](https://sciendo-parsed-data-feed.s3.eu-central-1.amazonaws.com/JEMUEKAT/Declaration_of_Copyright.pdf)

Upload other files to this section if necessary.

Upon receiving the final, camera-ready version, we will promptly process and forward it to our English and Publishing editors. Editors may contact you to resolve any uncertainties arising from unclear wording or linguistic errors.

We will be in touch if further information is needed during this process.

You can find the published papers here:

<https://sciendo.com/journal/JEMUEKAT>Sincerely,  
Prof. Ewa Ziemba, Editor-in-Chief of  
JEMDr. Monika Eisenhardt, Managing  
Editor

Journal of Economics and Management  
The University of Economics in Katowice,  
Polande-mail: [jem.submission@ue.katowice.pl](mailto:jem.submission@ue.katowice.pl)  
website: <https://sciendo.com/journal/JEMUEKAT>; [www.ue.katowice.pl/jem](http://www.ue.katowice.pl/jem)

12. Editor meminta untuk pengecekan tata tulis

13. Revisi tata tulis dinyatakan lolos

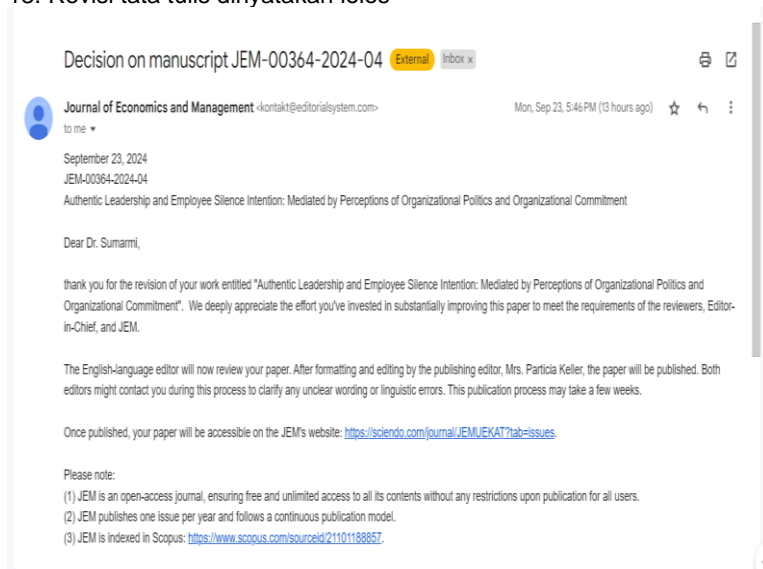

Decision on manuscript JEM-00364-2024-04 External Inbox x

Journal of Economics and Management <[kontakt@editorialsystem.com](mailto:kontakt@editorialsystem.com)> Mon, Sep 23, 5:46 PM (13 hours ago) ☆ ↶ ⋮  
to me ▾

September 23, 2024  
JEM-00364-2024-04  
Authentic Leadership and Employee Silence Intention: Mediated by Perceptions of Organizational Politics and Organizational Commitment

Dear Dr. Sumami,

thank you for the revision of your work entitled "Authentic Leadership and Employee Silence Intention: Mediated by Perceptions of Organizational Politics and Organizational Commitment". We deeply appreciate the effort you've invested in substantially improving this paper to meet the requirements of the reviewers, Editor-in-Chief, and JEM.

The English-language editor will now review your paper. After formatting and editing by the publishing editor, Mrs. Patricia Keller, the paper will be published. Both editors might contact you during this process to clarify any unclear wording or linguistic errors. This publication process may take a few weeks.

Once published, your paper will be accessible on the JEM's website: <https://sciendo.com/journal/JEMUEKAT?tab=issues>.

Please note:  
(1) JEM is an open-access journal, ensuring free and unlimited access to all its contents without any restrictions upon publication for all users.  
(2) JEM publishes one issue per year and follows a continuous publication model.  
(3) JEM is indexed in Scopus: <https://www.scopus.com/sourceid/21101188657>.